

Portable Automatic Gas Cutter



BEC00B20

IK-82 M-300

Concentrick Tracing Cutter

OPERATION MANUAL



For every person who will be engaged in operation and maintenance supervision, It is recommended to read through this manual before any operations, so as to permit optimum operation of this machine.

KOIKE SANZO KOGYO CO.,LTD.

INTRODUCTION

Thank you very much for purchasing this product. Read this instruction manual thoroughly to ensure correct, safe and effective use of the machine. Read the manual first to understand how to operate and maintain the machine. Cooperation between colleagues in the workplace is essential for safe, smooth operation. Make sure you read, understand and take all necessary safety precautions.

SAFETY PRECAUTIONS









This product is designed to be safe, but it can cause serious accidents if not operated correctly. Those who operate and repair this machine must read this manual thoroughly before operating, inspecting and maintaining the machine. Keep the manual near the machine so that anyone operates the machine can refer to it as necessary.

- Do not use the machine carelessly without following the instructions in the manual.
- Use the machine only after you have completely understood the contents of the manual.
- If an explanation in the manual is difficult to understand, contact our company or sales service office.
- Keep the manual to hand at all times and read it as many times as is necessary for a complete understanding.
- If the manual becomes lost or damaged, place an order with our company or sales service office for a new one.
- When transferring the machine to a new owner, be sure to hand over this instruction manual as well.

QUALIFICATIONS FOR MACHINE OPERATOR

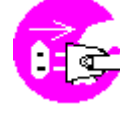
Operators and repair staff of this machine must completely understand the contents of the instruction manual and have either of the following qualifications:

1. Gas welding foremen's license
2. Completion of gas welding training course
3. Approval by the Minister of Labor

Symbol	Title	Meaning
	General	General caution, warning, and danger.
	Be careful not to get your fingers caught.	Possible injury to fingers if caught in the insertion port.
	Caution: Electric shock!	Possible electric shock under special conditions.
	Ground this equipment.	Operators must ground the equipment using the safety grounding terminal.
	Pull out the power plug from the outlet.	Operators must unplug the power plug from the outlet when a failure occurs or when there is a danger of lightning damage.
	Caution against bursting	Possible bursting under certain conditions.
	General	General warning.
	Caution: Hot!	Possible injury due to high temperature under certain conditions.
	Caution: Ignition!	Possible ignition under certain conditions.

CONTENTS

1. Safety Information	1
1.1 General machine safety precautions	1
1.2 Gas cutting safety precautions	3
2. Location of safety labels	5
3. Outline of machine	6
3.1 Features of machine	6
3.2 Name and function of each section	6
3.3 Specifications	7
4. Preparation for operation	8
4.1 Contents of package	8
4.2 Machine assembly	8
4.3 Preparation for operation	8
5. Cutting operation	11
5.1 Safety measures prior to operation	11
5.2 Ignition and flame adjustment	13
5.3 Cutting and piercing method	14
5.4 Procedures for starting cutting and extinguishing flame	14
5.5 Safety measures against backfire and flashback	15
5.6 Cutting operation	15
5.7 Option	16
6. Maintenance and inspection	17
6.1 Daily Checks	17
7. Troubleshooting	18
8. Wiring diagram	19
9. Assembly drawing of IK-82 M-300	19
10. Parts list	20
10.1 Main unit	20
10.2 Control panel	22
10.3 Tracer head	24
10.4 Torch	26
11. Cutting Data	28

1 Safety information

Many accidents are caused by operation, inspection, and maintenance which disregard the basic safety rules. Carefully read, understand, and master the safety measures and precautions described in this instruction manual and on the machine before operating, inspecting, and maintaining the machine.

The safety messages are classified as follows for machine safety labels:

■ **WARNING**

This word is used in a warning message and a warning label at places that could cause injury or serious accident.

■ **CAUTION**

This word is used in a caution message and a caution label at places that could cause slight injury or machine damage. This is also used as a caution for frequent dangerous actions.

■ **NOTICE SIGNS**

This is a sign to show machine operators and maintenance engineers items that relate directly to damage of machines and surrounding facilities and equipment.

1.1 General machine safety precautions

Read and fully understand the following important safety information:

1.1.1 Machine safety

1. The machine casing is mainly made of aluminum alloy to reduce weight. For this reason, be careful not to drop a heavy item on the machine, or not drop the machine when carrying it, since the alloy is not designed to withstand such impact.
2. When mounting hoses to the torch and distributor, tighten the nut with the attached wrench. After mounting, be sure to check there is no gas leak with a detection liquid. If a gas leak is found, retighten the nut firmly.
3. When fixing a tip to the torch, tighten the nut with the two wrenches attached. In addition, avoid damaging the taper of the tip since this may cause backfire.
4. Never disassemble the machine other than during maintenance and inspection. Otherwise, malfunction will result.
5. Never remodel the machine. Remodeling is very dangerous.
6. When changing the direction, make sure that the direction switch is in the neutral (stop) position, and operate the direction switch after the machine has stopped.
7. Always turn the power off when not in use.
8. Never use the machine outdoors when the weather is wet. This will cause failure of the machine and could cause a fatal accident by electric shock.

1.1.2 Safety clothing

1. Be sure to wear protector's gauntlets, goggles, helmet, and safety shoes during operation.
2. Avoid operating the machine with wet clothes or hands in order to prevent electric shock.

1.1.3 Operation and handling safety precautions

1. Read this instruction manual before operating the machine.
2. Mount and center the machine correctly and confirm correct motion before operation.
3. Before connecting the power plug to the outlet, make sure that the power switch is in the OFF position (or the normal/reverse changeover switch is in the stop position).
4. Prior to operating the machine, check the safety of the surroundings to avoid accidents.
5. Never move the machine while the preheat flame is on.
6. Take great care of spatters and drops when operating the machine at a high position. They may injure people below.
7. When the machine will not be used for cutting, turn off the magnet switch
8. Be sure to fix the magnet for securing the machine before starting cutting operation.
9. Be sure to secure the leg with a curved handle.
10. When carrying the machine, pay attention to the movement of the tracer head.
11. Be sure to fix the wing nut for securing the tracer head during cutting operation.
12. When storing or carrying the machine, set the arm in the ring attached to the leg.
13. be sure to hold the handle when carrying the machine.

1.1.4 Electrical system precautions



1. Be sure to check the input power voltage of the machine before operation. The input power voltage should be in the range of $\pm 10\%$ of the rated voltage. The machine should not be operated out of this range.
2. The metal plugs are screw-threaded, therefore, fully tighten them so that they will not come loose during operation.
3. The ground pin is attached to the rubber plug of a cable. Please use a power receptacle with a ground pin opening
4. **Stop operation and turn off the power in the following cases, and ask a qualified electrician to repair the machine.**

 - 1) Broken or abraded cables
 - 2) Water leakage from the machine or liquid damage to the machine
 - 3) Abnormal machine operation despite operating the machine according to the instruction manual
 - 4) Machine breakdown
 - 5) Poor machine performance that requires repair
5. Periodically inspect the electrical system.

1.1.5 Maintenance and inspection precautions



1. Ask a qualified electrician to perform repair and inspection service.
2. Disconnect the power plug before inspecting and repairing the machine.
3. Maintain the machine periodically.

1.2 Gas cutting safety precautions

Strictly observe the safety rules and precautions to ensure the safety of gas cutting operations. Operators and supervisors MUST keep safety in mind.

1.2.1 Prevention of explosion



1. Never cut pressurized cylinders or hermetically sealed containers.
2. Ensure sufficient ventilation for gas cutting to prevent the air from becoming stale.

1.2.2 Pressure regulator safety precautions



1. Before starting operation, check that all pressure regulators are operating correctly.
2. Ask a skilled repair engineer to perform maintenance and inspection service.
3. Do not use pressure regulators from which gas is leaking, nor malfunctioning pressure regulators.
4. Do not use pressure regulators smeared with oil or grease.

1.2.3 High Pressure gas cylinder safety precautions



1. Never use broken cylinders or cylinders from which gas is leaking.
2. Install cylinders upright and take measures to prevent them from falling.
3. Use cylinders only for specified purposes.
4. Do not smear container valves with oil or grease.
5. Install cylinders in a place free from heat, sparks, slag, and naked flame.
6. Contact the distributor if the container valves will not open.
Never use a hammer, wrench, or other tools to forcibly open container valves.

1.2.4 Safety precautions for hoses



1. Use the oxygen hose for oxygen gas only.
2. Replace cracked hoses or other hoses damaged by sparks, heat, unshielded fire, etc.
3. Install hoses without twisting.
4. To prevent breakage of hoses, take great care during operation and transportation.
5. Do not hold the hoses when moving the machine.
6. Periodically check the hoses for damage, leakage, fatigue, loose joints, etc, to ensure safety.
7. Cut hoses to the minimum possible length. Short hoses reduce hose damage and pressure drop, as well as reduce the flow resistance.

1.2.5 Safety precautions for fire



Take safety precautions to prevent fire prior to gas cutting. Ignoring hot metal, sparks, and slag could cause a fire.

1. Keep a fire extinguisher, fire extinguish sand, bucket full of water, etc. ready on the site where gas cutting is performed.
2. Keep flammables away from the cutting area to avoid exposure to sparks.
3. Always cool steel plates that have become hot after cutting, as well as hot cut parts or scrap, before bringing them close to flammables.
4. Never cut containers to which flammable materials are stuck.

1.2.6 Safety precautions for skin burns



Observe the safety precautions to prevent skin burns. Ignoring heat, spatter, and sparks during operation could cause a fire or burned skin.

1. Do not perform cutting near flammables. (Move flammables well away from the sparks.)
2. Do not cut containers filled with flammables.
3. Do not keep lighters, matches, and other flammables nearby.
4. Flames from the torch will burn the skin. Keep your body away from the torch and tip, and check the safety before operating the switches and valves.
5. Wear the correct protectors to protect your eyes and body.
6. Correctly tighten the tip to prevent backfire.
 - When fixing a tip to the torch, tighten the nut with the two wrenches attached.
 - If the tip is tightened excessively, it will be heated during cutting and tightened still more, making it difficult to remove the tip.
 - Avoid damaging the taper of the tip since this may cause backfire.
7. Check with soapsuds for any leakage of gas from the connection part of the distributor, hose and torch. Never use oil or grease on the connection of the oxygen pipe to avoid backfire which may lead to explosion.
8. Be sure to check the following when igniting:
 - Place the torch on the torch holder before igniting.
 - Always wear the required protectors (gauntlets, helmet, goggles, etc.)
 - Check for any obstacles, dangerous materials and flammables near or in the direction of cutting. Determine the gas pressure.
 - The gas pressure must be within the appropriate range. (For the gas pressure, refer to the Cutting Data.)
9. The torch, tip and heat shield are heated to a very high temperature. Always wear gauntlets when handling them. Also the surface after cutting is very hot so do not touch it even while wearing gauntlets.
10. Never move the machine while the preheat flame is on.

2 Locations of safety labels

Safety labels and other labels for correct operation are affixed to the machine.
 Carefully read the labels and follow the instructions on them when operating the machine.
 Never remove the labels. Keep them clean and legible at all times.

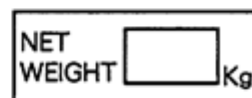
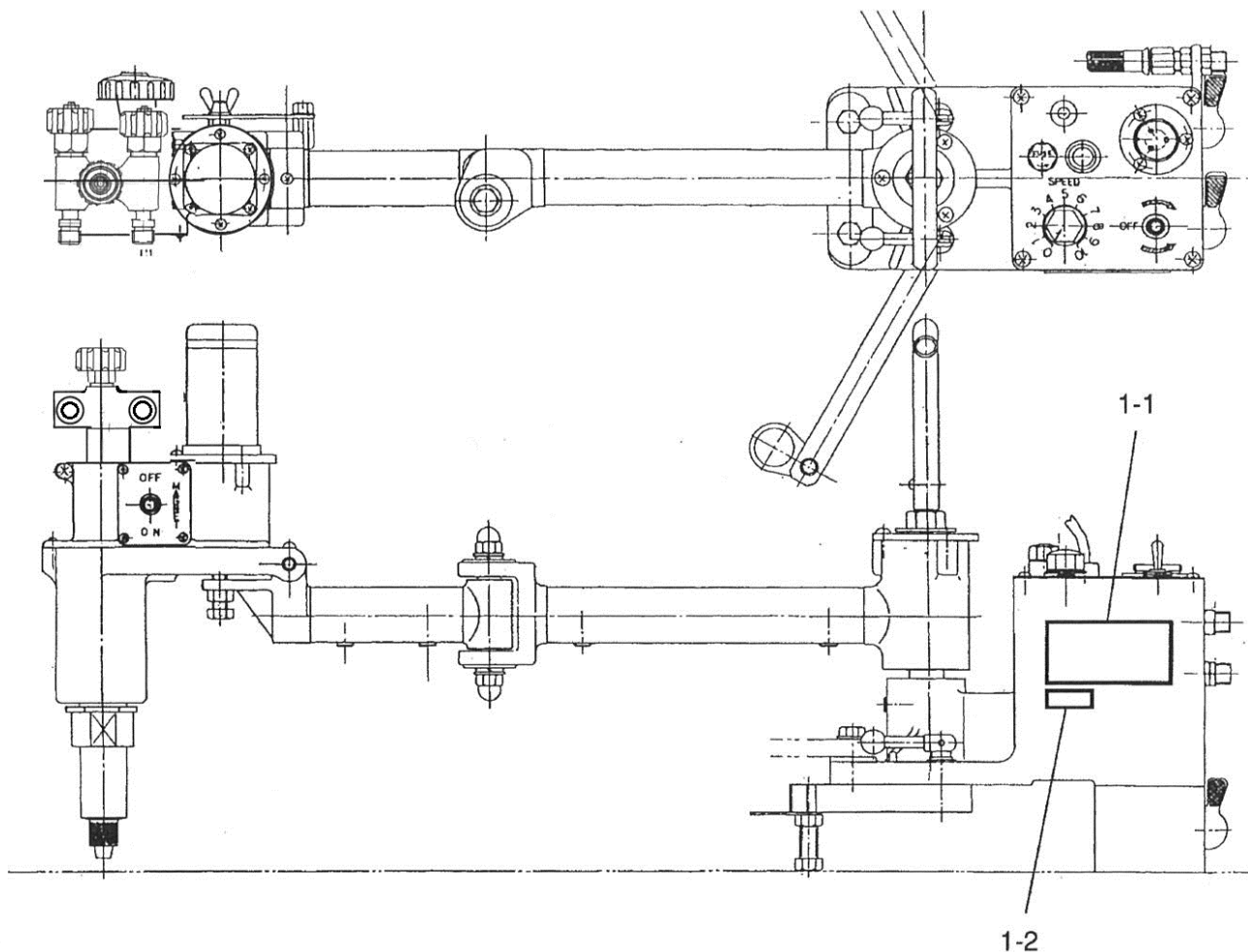

1-1

1-2

3 Outline of machine

3.1 Features of machine

IK-82 is a new and powerful mold cutting series of a concentric tracing type. The simple design and interchangeable construction have substantially reduced the machine weight and permitted systematization for easy use.

The model comes in two types The type can be to select according to size of material to be cut.

Enjoy advanced mold cutting with this IK-82 series.

3.2 Name and function of each section

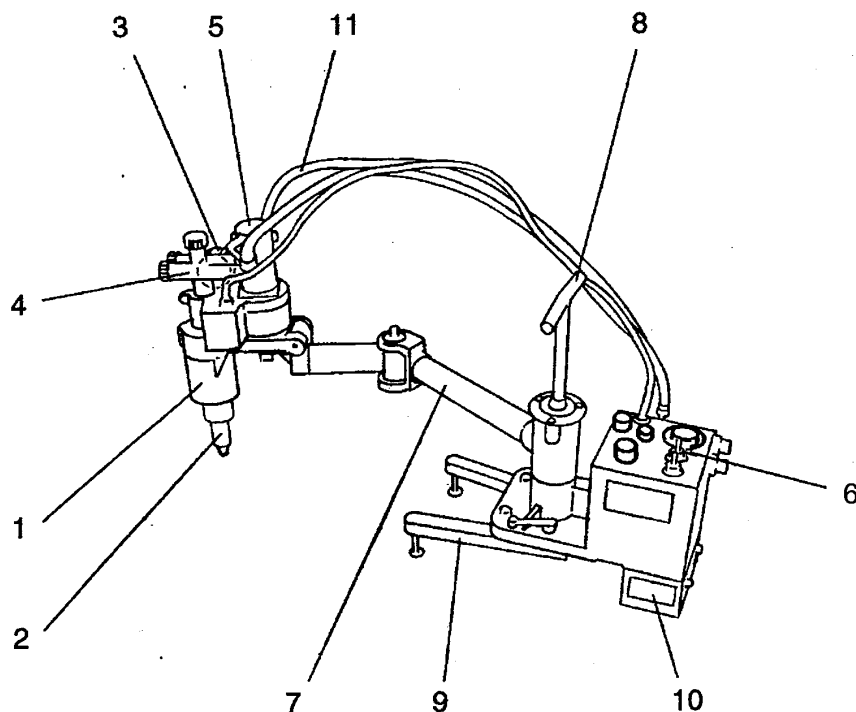

1. Tracer head

Holds the torch and moves along a mold.

2. Magnet roller

Turns and moves along a mold.

3. Torch up/down handle

Moves the torch up and down.

4. Torch

5. Motor

6. Magnet ON-OFF switch

Turns on and off the magnetism.

7. Arm

8. Handle

9. Leg

10. Magnet

11. Hose

3.3 Specifications

Total Weight	9.5kg
Power supply	±10%
Cutting speed	100-600mm/min
Effective cutting range	300 dia. circle 600x200 oval
Machine securing	50 kg magnet with detaching lever
Magnet roller	16 dia.
Cutting thickness	5-30mm (reference value when using the tip No.0-2)
Tip	Type 400 1/300 speed reducer
Gas	Oxygen, acetylene, or LPG

●Accessories

• Tip (Type 400) Nos. 0, 1, 2	1 pc each
• Tip cleaner	1set
• Spanner (A,B,C, and F)	1set
• Screw drive	1 pc
• Fuse (2A)	2pcs
• Brush	1pc
• Cabtyre cord	1pc
• Lighter	1pc

●Option

• Magnet roller	25 dia.
-----------------	---------

4 Preparation for operation

4.1 Contents of package

The following are in the packing. Check them before assembling the machine.

• Body	1set
• Torch	1pc
• Distribution hose (2-piece set:700L)	1set
• Cabtyre cord (3Px5M)	1pc
• Tip (type 400) 402 or 406 Nos. 0, 1, 2	1pc each
• Tip cleaner	1set
• Screwdriver	1pc
• Spanner (4pcs)	1set
• Fuse (2A)	2pcs
• Brush	1pc
• Lighter	1pc

4.2 Machine assembly

1. Carefully take the machine out of its case.
2. Carefully check that the torch holder, gas distributor, torch, etc. are in position.
3. Attach the primary hose to the gas distributor.
 - OX hose
 - Gas hose

4.3 Preparation for operation



4.3.1 Connecting the power cable

1. Connect the power cable to the body.
2. Before plugging the metal plug on the cabtyre cord side into the socket on the machine side, check there is no dust inside.
3. The metal plugs are screw-threaded, therefore fully tighten them so that they will not come loose during operation.

4.3.2 Connecting the gas supply hose

1. Connect the respective gas supply hoses to the primary hose.
2. Securely tighten the joints and check there is no gas leak.

4.3.3 Connecting the tip

1. Select a proper tip according to the thickness of the steel plate and attach it to the torch.
(To select a tip, refer to the table of cutting data.)
 - When fixing a tip to the torch, tighten the nut with the two wrenches attached.
 - If the tip is tightened excessively, it will be heated during cutting and tightened still more, making it difficult to remove the tip.
 - In addition, avoid damaging the taper of the tip since this may cause backfire.
2. Lift the tracer head.
3. Let the torch out with the torch up/down handle.
4. Attach the tip.
5. Secure the tip tightening nut and return the tracer head to the upright position.

4.3.4 Making Template

The torch moves on the locus of the magnetic roller. Cut the rough template shape taking into consideration the magnetic roller diameter and width of cutting loss for accurate shape cutting when making template.

1. Caution when making template.

- Template defect may cause faulty cutting.
- In general, adopt an inner tracing template. (IF an outer tracing template is used, it may fall with the cutting machine when cutting is completed.)
- Make template from plate 6mm thick.
- Remember when making calculations that width of cutting loss is determined by nozzle size.

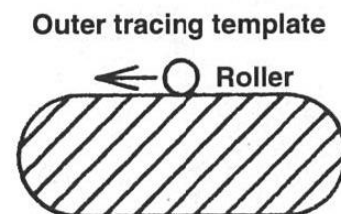
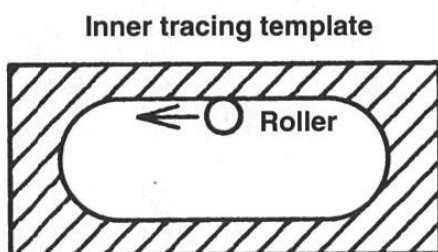

Example 1

When outer part by cutting is a product.
To cut 100mm dia. hole in 12mm thick plate.

- Kerf width and tip No.#1

$$1.2 \times 1.6 = 2\text{mm}$$

$$\phi 100 + \phi 16 - 2 = \phi 114$$

Product dimension + roller dia. - Kerf width = Template dimension

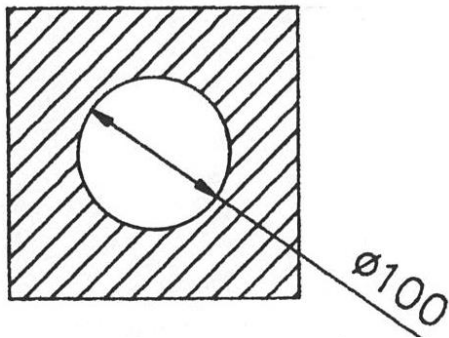
**Example 2**

When inner part by cutting is a product.
To cut 12mm thick 100mm dia. plate.

- kerf width and tip No.#1

$$1.2 \times 1.6 = 2\text{mm}$$

$$\phi 100 + \phi 16 + 2 = \phi 118$$

Product dimension + roller dia. + Kerf width = Template dimension

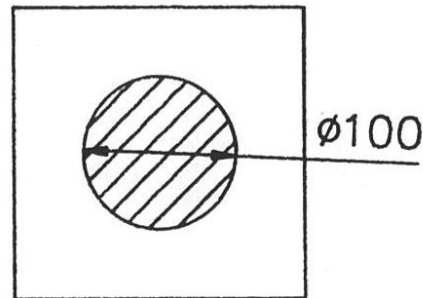
**2. Template****1) Placed type template**

The template should have enough weight or be equipped with a clamp to prevent it from being drawn up by the magnetic roller or from moving.

The template should be made in such a way that the template bottom surface matches with the roller bottom surface.

2) Mounted type template

Make mounting holes in the template as shown below when mounting template to cutting machine.

Use the tapped holes (M8) in the cutting machine to mount the template.

Provide the template supporters to improve the cutting machine steadiness as required at the position where the supporters do not interfere with the magnetic roller movement when the template size is large.

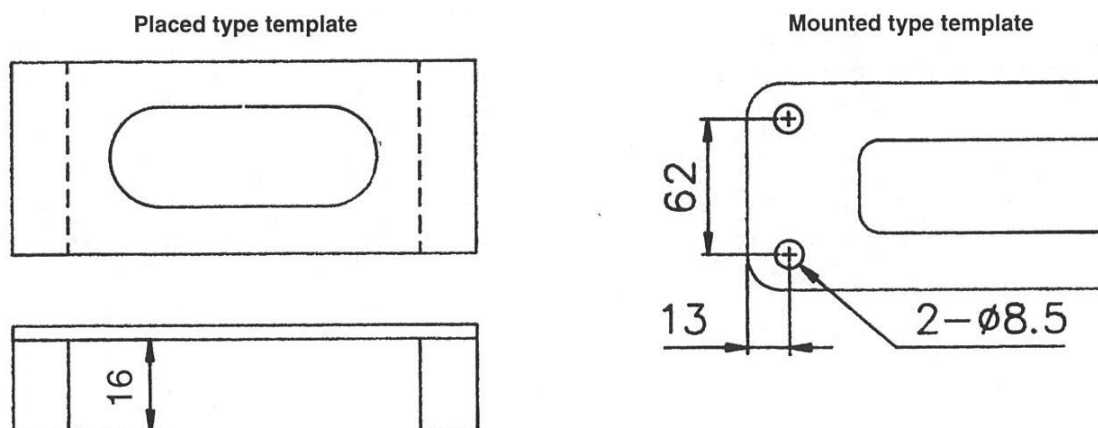

- * When the magnetic roller diameter is $\phi 16$, the template is 16 mm high.
- When the magnetic roller diameter is $\phi 25$, the template is 66mm high.

IK-82 M-300 Cutting range

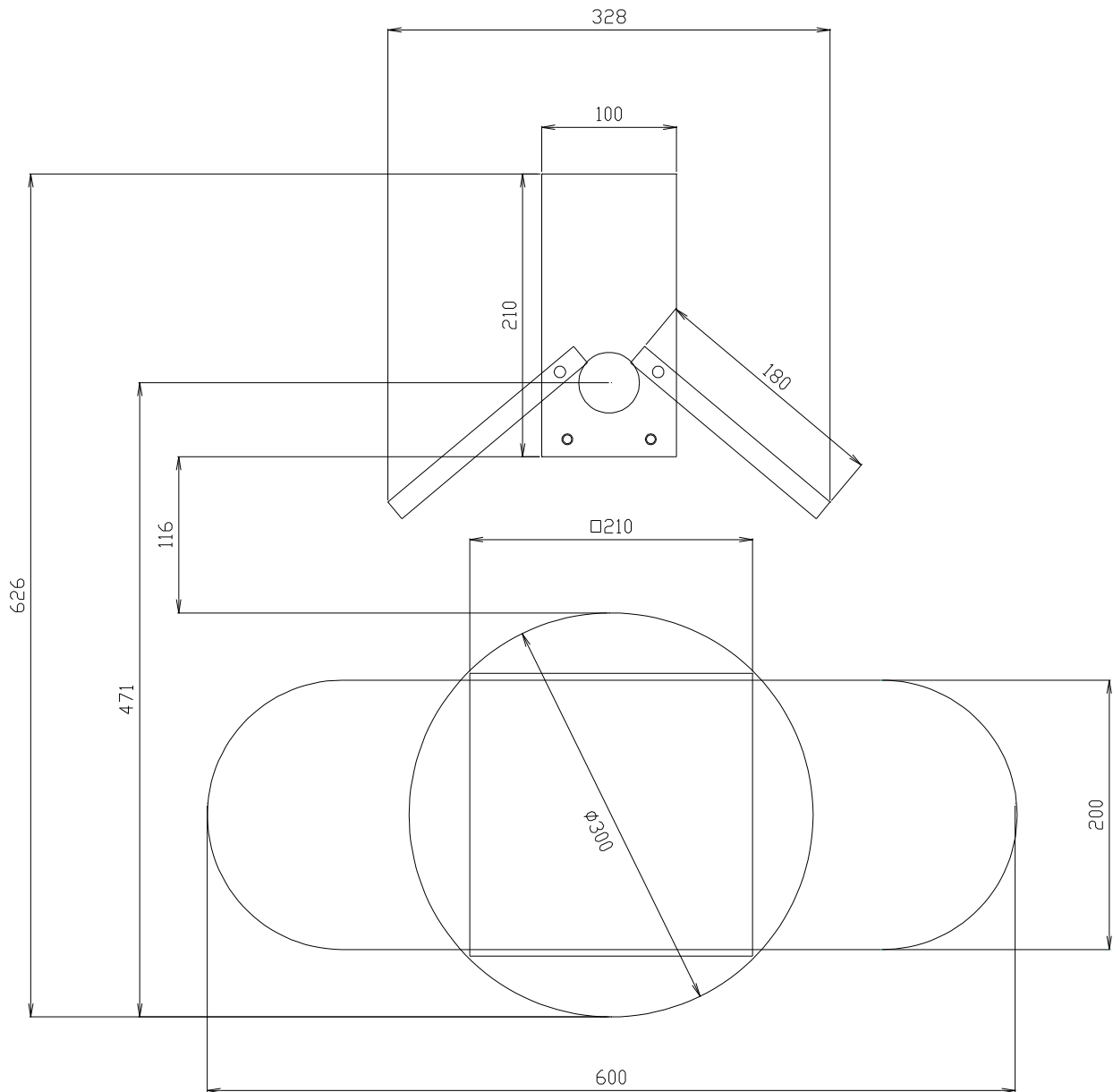

5 Cutting operation

5.1 Safety measures prior to operation

5.1.1 Check for gas leaks at each connection

This machine is a gas cutting machine. Before use, please pay careful attention to the gas connection part, and make sure to conduct a gas leak inspection and use it safely.

- There are the following nut tightening operations for connecting the torch and tip. Please be careful not to mistake the procedure.

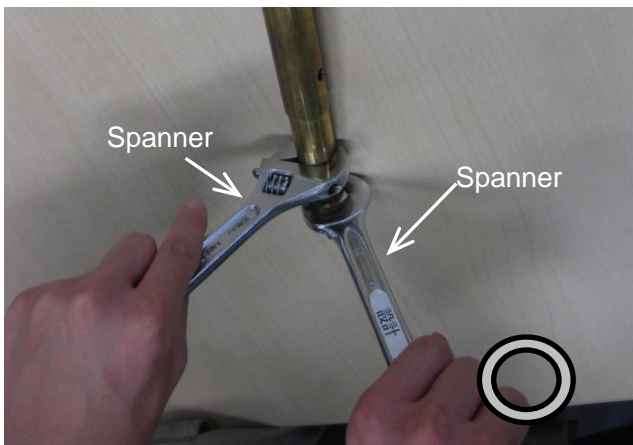

Correct

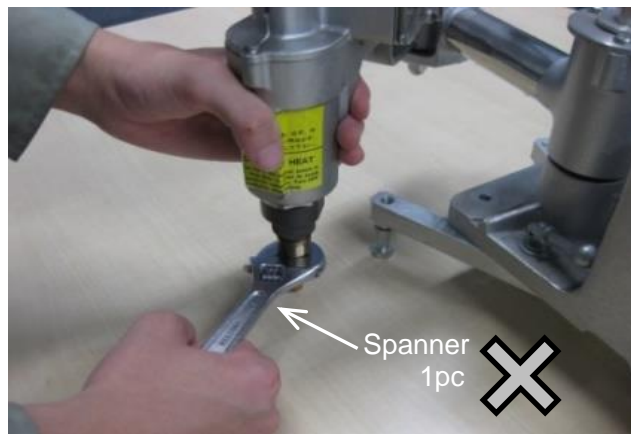

Incorrect

As shown in the figure, pull out the torch from the tracer head and tighten the tip fixing nut with two spanners.

The gas joint has the following locations. Use a gas detection liquid or soapy water to check for gas leaks. Also be sure to use two wrench of appropriate size when tightening the nut of each joint.

- Please refer to the following items and figures for the location to check for gas leaks.

a) Primary hose connection part

b) Joint nipple and connection part of each hose

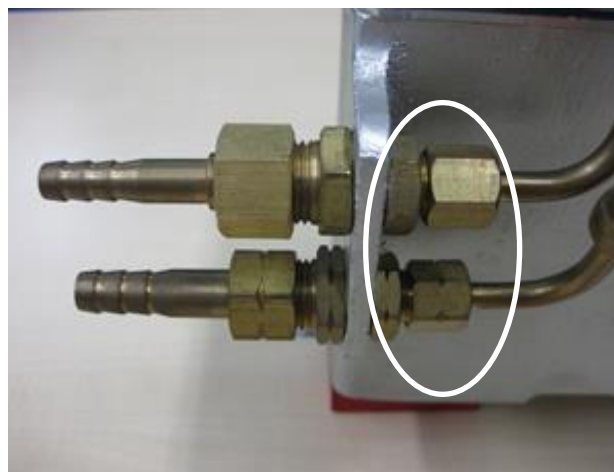
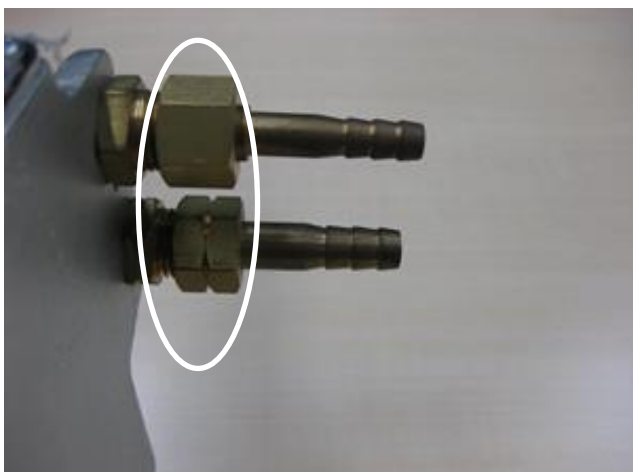

c) Torch gas inlet and secondary hose connection



d) Check for leaks from each valve mounting and valve spindle.



e) Check for gas leaks from holes in the side of the torch body (*1)

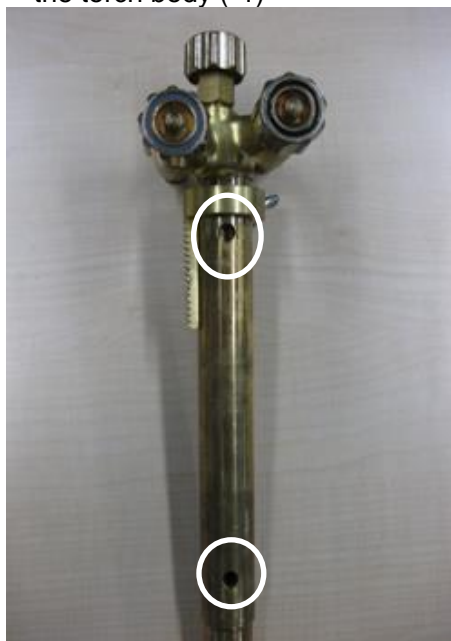

Overall view

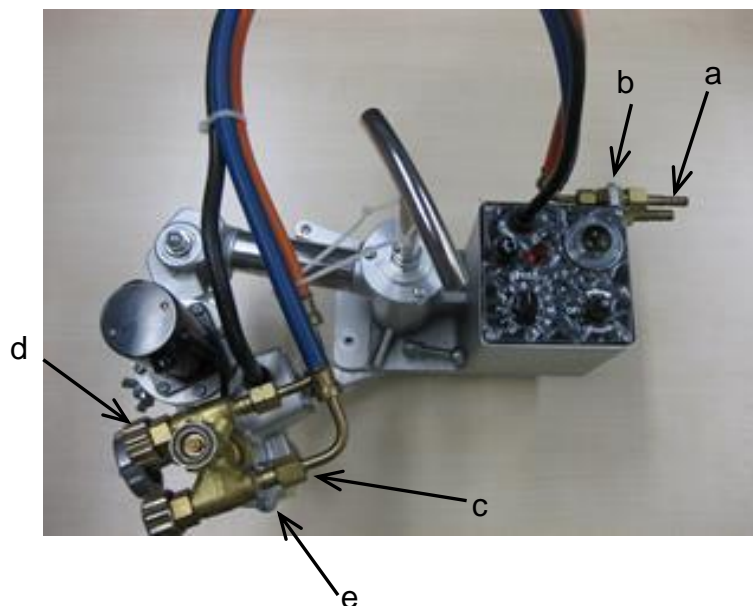

(*1) Please check with the tip attached and the gas ignited.

■ Tightning the tip fixing nut and checking for gas leakage.

- When tightning the cip fixing nut, first insert a spanner into the two chamfered portion of the torch body to secure the torch body. Next, insert another spanner into the two chamfered parts of the tip fixing nut abd tighten it with a torque of 25N · m.
- Use a gas detection liquid or soapy water to the tip fixing nut, and check for gas leaks.

Note) If there are scratches or rther foreign objects in the tip area or the tip area of the torch body, gas may leak even if the tip fixing nut is tightened. If the gas is leaking from the tip fixing nut, **the IK-82 main unit be filled with gas, which is very dangerous.**

When replacing the tip, be sure to pull out the torch from the IK-82 body, replace the tip, and make sure that there is no gas leakage from the tip fixing nut.

(With the tip attached and the gas ignited, run the detection or soapy water through the tip fixing nut and check.)



5.1.2 Grounding the machine

The cable of this machine is equipped with a grounding wire. For safety, be sure to ground the wire as follows, in addition to checking the connection of the power cable.

■ Method to ground the machine

- The ground pin is attached to the rubber plug of a cable cord. Please use a power receptacle with a ground pin opening.

5.1.3 Selection of tip

Referring to the Cutting Data, select the suitable tip according to the plate thickness.

For a heavily rusted plate or for a bevel cutting angle of more than 20° , select the tip one grade higher than the one shown in the Cutting Data.



5.1.4 Operation of running direction changeover switch

- Use the directional changeover switch to change the direction of rotation. The machine is at rest when the switch is in the OFF position.
- When changing the running direction, be sure to return the changeover switch to the OFF position. After the machine has stopped once, change the running direction.
- Be sure to set the switch in the OFF position unless the machine is to be moved.
- Set the directional changeover switch in the OFF position when turning on the power. When the switch is in the clockwise or counterclockwise turning position, the machine will begin to move, which is very dangerous.
- Never put your hand between the magnet roller and the mold when the machine is traveling, otherwise your hand may be caught between them.

5.2 Ignition and flame adjustment

- Adjust the gas pressure according to the Cutting Data. The data shows the pressure when all the valves are open. Readjust the pressure after ignition. (See page 28)

■ Flame adjustment method

1. Open the fuel gas valve $1/4$ to $1/2$ a turn, and light the torch with an igniter.
2. Then, open the preheating oxygen valve gradually until a white cone of the standard flame has been obtained. (The incandescent area should be uniform and about 5-6mm ($3/16$ - $1/4$ ") in length)
3. Open the jet oxygen valve fully. Readjust the flame if its condition has changed. A disorderly flow of the jet oxygen will adversely affect the quality of the cutting surface. In such a case, clean the tip with a suitable cleaning needle while the jet oxygen is flowing.
4. Appropriate distance between the tip end and cutting surface
 - Acetylene gas8-10mm
 - LPG gas5-8mm

Neutral flame ensures good quality cut surfaces. (Oxygen flame may be used for bevel cutting.)

Oxygen flame causes short cutting-oxygen current, allowing slugs to adhere, melting the upper edge of the cutting surface, and causing other adverse effects on the cut surface. Similar defects will result when the cutting oxygen pressure is too high.

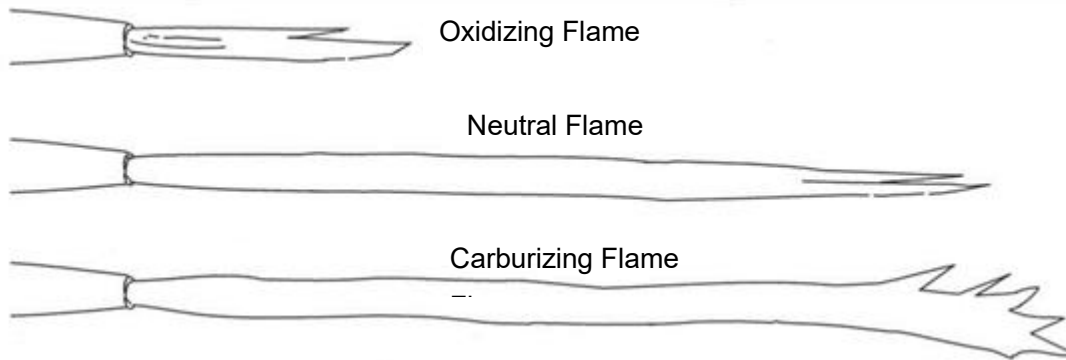

5.3 Cutting and piercing method

1. Cut in from the end of steel plate.
2. Pierce steel plate before cutting.
3. Drill a hole before cutting.

■piercing method

- 1) Ignite and adjust the flame.
- 2) Thoroughly preheat the cut-in point until it is white hot.
- 3) Open the cutting oxygen valve to pierce the steel plate. The tip should be about 15-20 mm from the plate to prevent slag from splashing onto the tip and adhering there, which will shorten the working life of the tip.

5.4 Procedures for starting cutting operation and extinguishing the flame

1. Align the tip with the cutting start point, ignite, and then adjust the flame.
2. Sufficiently preheat the cutting start point.
3. After preheating, supply oxygen and simultaneously turn on the motor switch or the turning direction switch to start cutting.
4. Carefully check the cutting condition, and control the cutting speed with the speed adjuster.
For the cutting speed, refer to the Cutting Data.
5. Extinguish the flame after cutting as follows:
 - 1) Turn off the motor switch (or turning direction switch).
 - 2) Close the cutting oxygen valve.
 - 3) Close the preheating oxygen valve.
 - 4) Close the fuel gas valve.

5.5 Safety measures against backfire and flashback

5.5.1 Prevention of backfire

Backfires may cause serious accidents or fires. Be careful to prevent such disaster. When a backfire occurs, find the cause and inspect and maintain the machine correctly before using the machine again.

The following are causes of backfire:

- 1) Improper gas pressure adjustment
- 2) Overheated tip
- 3) Slag clogged in tip
- 4) Damage to the tapered section of the tip or torch will cause backfire

5.5.2 Prevention of flashback

Flashback could cause fire and break the machine. Should there be a hissing sound in the torch, quickly take the following.

Action:

- 1) Close the preheating oxygen valve.
- 2) Close the fuel gas valve.
- 3) Close the cutting oxygen valve.

Should flashback occur, find the cause and take appropriate action before using the machine again.

5.6 Cutting operation

1. Set a template according to the cutting section.
2. Set the machine according to the template. In that case, check that the arm can move freely covering the entire cutting section of the template.
3. Then follow the aforementioned procedure for ignition and flame adjustment.
4. Adjust the tip height from the steel sheet. (2-3mm from the tip of the white point.)
5. Turn on the power, and begin piercing or edge cutting, proceeding to regular cutting operation. (When piercing method is adopted, keep the tip approx. 15 mm away from the steel sheet to prevent the tip from burning during piercing. After piercing, adjust the distance between the tip and steel sheet for regular cutting operation.)
6. Manually cut the template until the magnet roller touches the template. When the magnet roller touches the template, turn ON the electromagnetic switch in the upper section of the tracer head. Then the magnetic field will be generated and cutting will begin along the template.
7. When cutting has begun, carefully observe the cutting conditions, and adjust the cutting speed so that it will be optimal.
8. After cutting, close the cutting oxygen valve, turn off the drive switch, and then close the gas valve and the preheating oxygen valve in that order.

5.7 Option

5.7.1 Replacing of magnet roller

Please use 2ea furnished spanners for mounting & dismounting of the magnet roller.

(The magnet roller is interchangeable between IK-82S & 82M, due to the same tracer head have been used for both of them. However, if the magnet roller of IK-82S has used for IK-82M, the tracing speed, template and tracer head height will be same as IK-82S.)

*When the magnetic roller diameter is $\phi 25$, the template is 66mm high.

- Hold the lock nut & magnet roller with 2ea spanners them loosen only lock nut on the magnet roller. (Fig.-1)
- Tight the lock nut to tracer body then take off the magnet roller while holding the lock nut with spanner. (Fig.-2)
- Tight the new lock nut to tracer body by hands.
After tighten, loose the lock nut with 1 opposite rotation.
- Loose the lock nut from tracer body them tight the magnet roller. (Fig.-3)

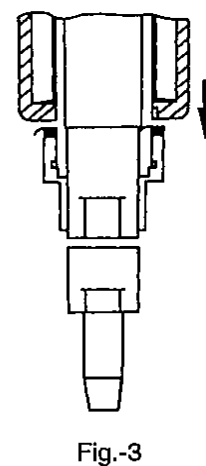
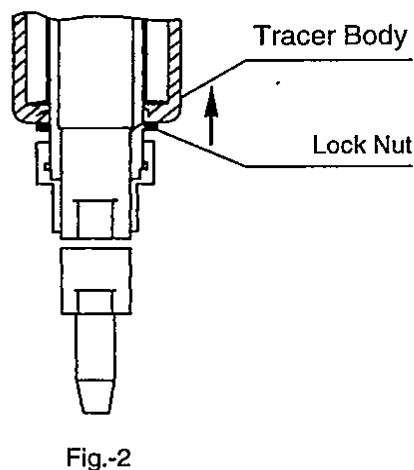
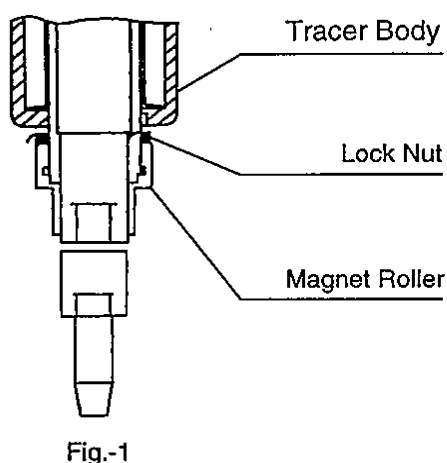

Remarks

After replacing the magnet roller, please make sure to tighten the lock nut on the magnet roller side so as not to be loosened.

If it have loosened, the magnet roller will run idle during operation, sticking on the tracer side, locking the rotary axis, and thus causing trouble on the reducer, motor and others.

While the replacing of magnet roller, please make sure to use the 2ea specific spanners which have provided with machine unit for setting & removing of the roller. Otherwise, it will be the reason for destruction of reducer, motor and others.

6 Maintenance and inspection

6.1 Daily Checks

Conduct routine checks to obtain the best results from the cutting machine.

- Clean off any dust or other foreign matters on the machine exterior with clean cloth.
- Make sure that arm joint turns smoothly.
- Keep the magnetic roller knurled part clean.(Foreign matter on the knurled part may cause knocking)
- Wipe off steel powder from magnet on the bottom of the machine
- Motor rotates, but its speed cannot be adjusted.
 1. Faulty variable resistor....Check resistance with a circuit tester.
 2. Faulty transistorReplace.

7 Troubleshooting

Problem	Cause	Inspection and repair
1) Motor does not rotate	1) Power is not supplied to motor	Check power voltage with a circuit tester.
	2) Faulty drive switch	-Ditto-
	3) Fuse blows	Visual check
	4) Faulty variable resistor	Check resistance with circuit tester
	5) Faulty rectifier	Replace
	6) Faulty motor	Check resistance with a circuit tester.
	7) Faulty reduction gears	Visual check
	8) Faulty transistor	Replace
2) Motor rotates at excessive high speed	1) Faulty transistor	Replace
3) Electromagnet does not work	1) Faulty silicon stack	Replace
	2) Faulty magnetic coil	Check resistance with a circuit tester.
	3) Faulty electromagnet switch	Check resistance with a circuit tester.
4) Cut surface defect	1) Faulty tip Make sure that the frame is neutral flame and sufficient cutting oxygen is supplied.	Clean tip with a cleaning needle or replace.
	2) Traveling speed is incorrectly set.	Check cutting condition and adjust traveling speed to optimum value.
	3) Faulty magnetic roller. • Foreign matter attaches to magnetic roller. • Magnetic roller wear.	Clean magnetic roller or replace.
	4) Arm does not move correctly. (Magnetic roller moves correctly)	Foreign matter attaches to joints connecting spindle and first arm, and first and second arms.

CAUTION

Power Controller

There is a controller attached to the machine using the power source voltage 200-240V. Please connect this machine controller to the machine connector. Please make an examination of this controller after connecting to the machine. Please take a lot of care that when you check with tester unless connecting to the machine, input voltage are checked as it is, output voltage is the same as input voltage.(This is not a fault)

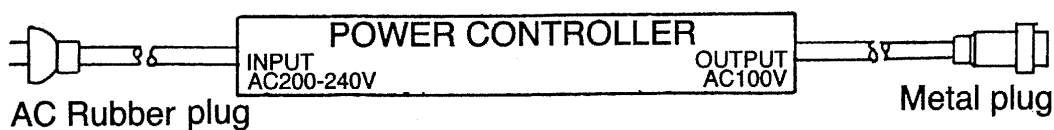

8 Wiring diagram

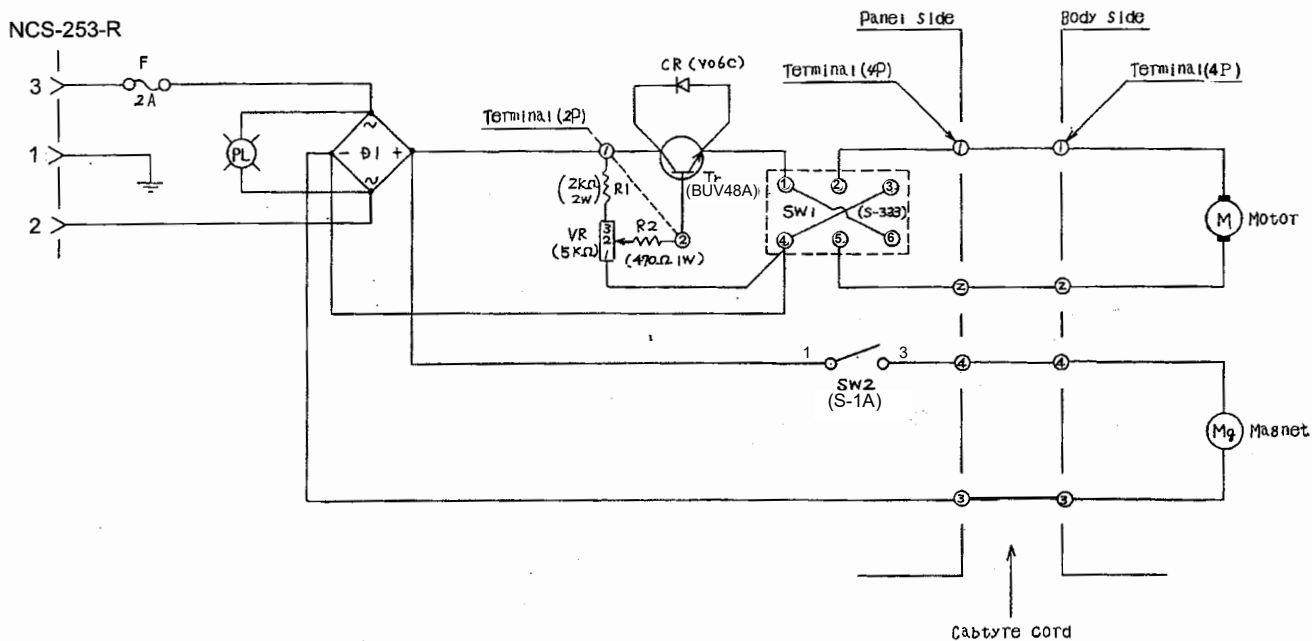

9 Assembly drawing of IK-82 M-300

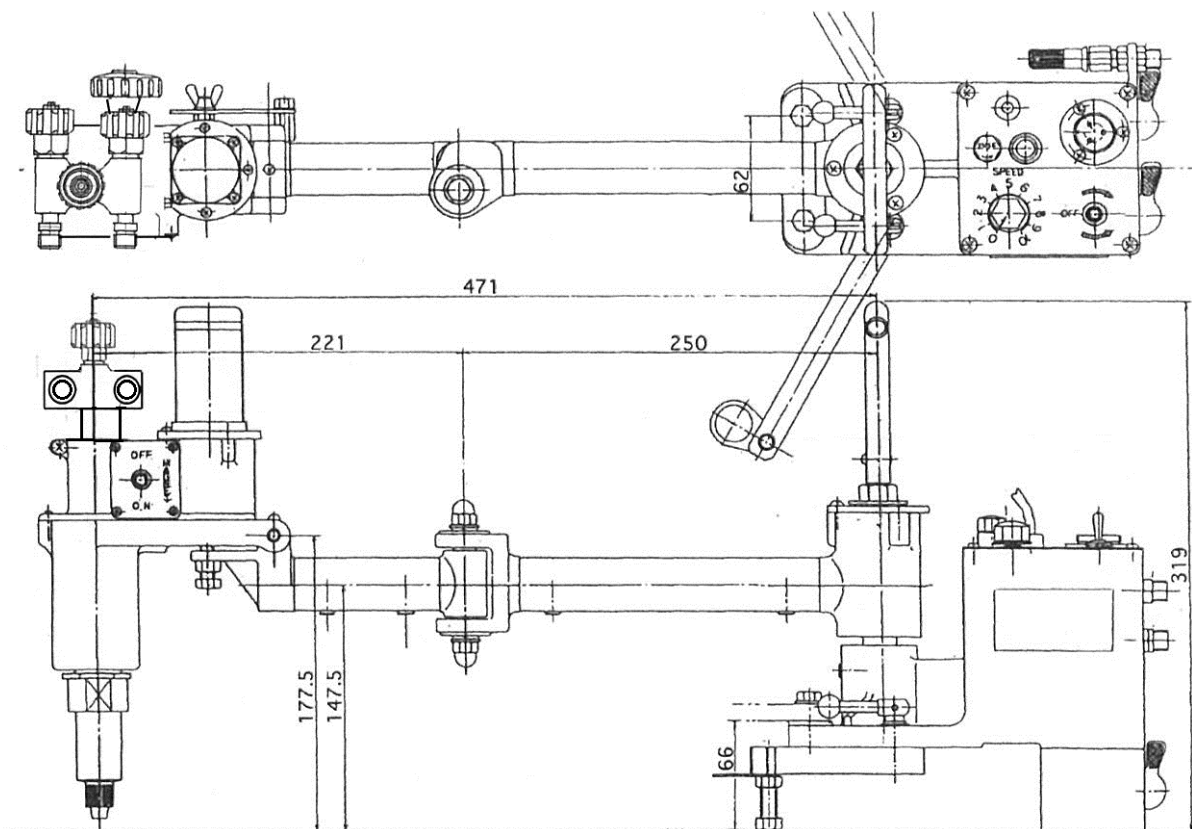

10 Parts List

10.1 Main Unit

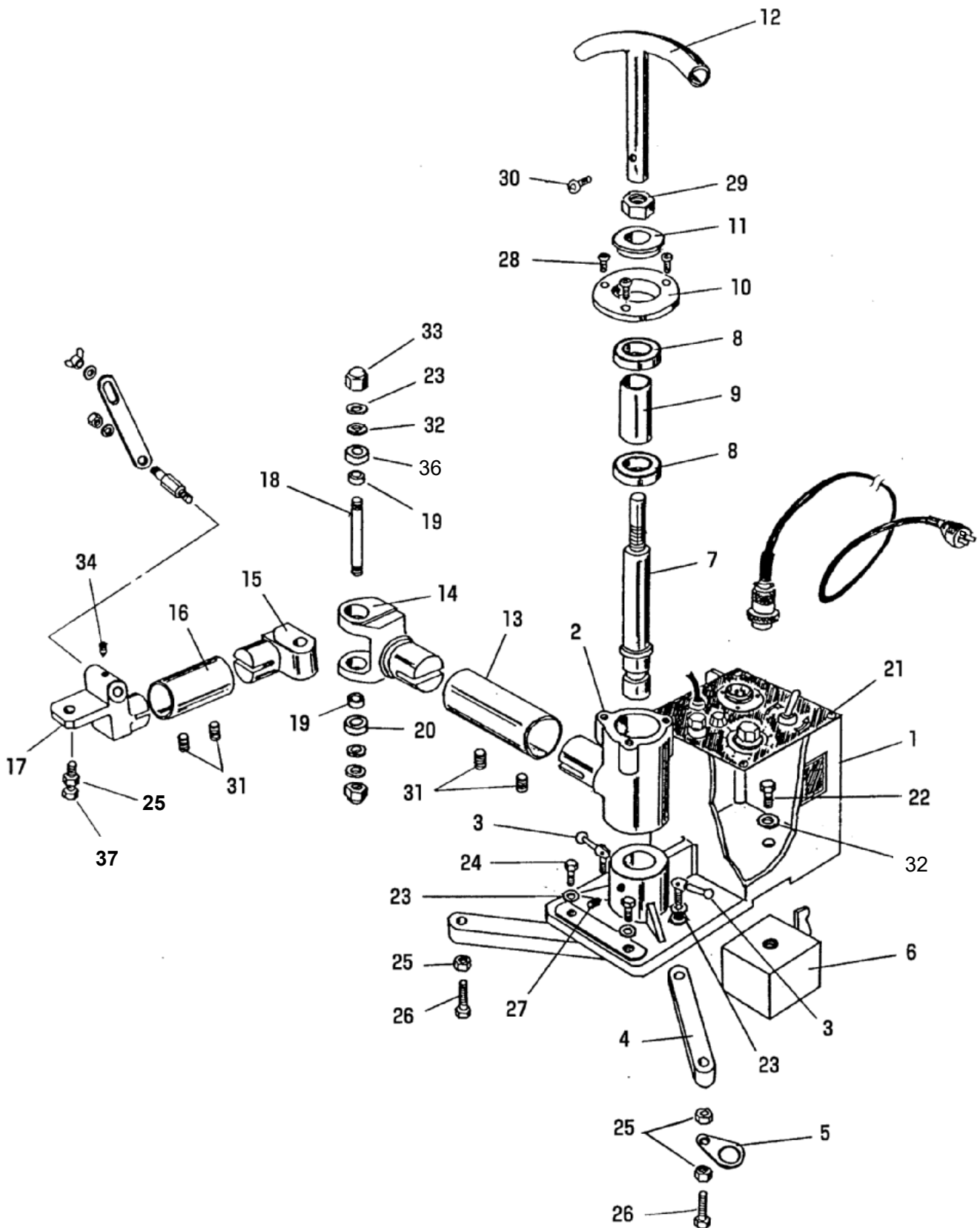

10.2 Control Panel

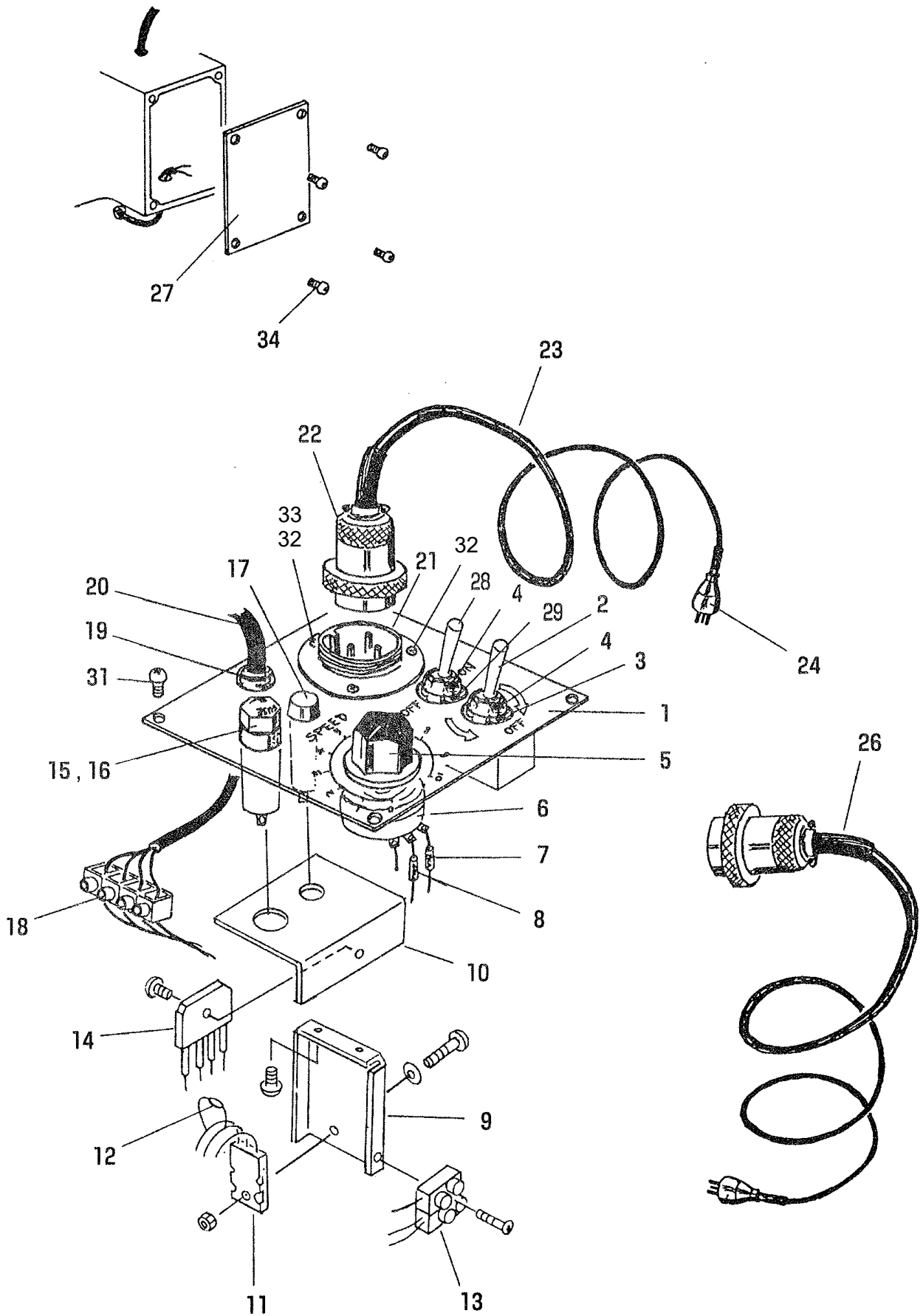

Control Panel

ITEM No.	PART NAME	QTY	STOCK No.	REMARKS	ITEM No.	PART NAME	QTY	STOCK No.	REMARKS
1	Control Panel	1	60033469		27	Cover plate	1	60033470	
	Control Panel	1	60033473	42V KE only	28	Switch	1	61006768	S-1A ★
2	Switch	1	60035226	S-333	29	Nut for dust protector	1	60035017	
3	Nut for dust protector	1	60032480		30	Terminal	1	60030656	4P
4	Cap for dust protector	2	60032431		31	Screw	4	6C520408	SP-4x8
5	Handle	1	60031249		32	Screw	3	6C500310	SF-3X10
6	Variable resistor	1	60033527		33	Nut	1	6D010030	NH-3
7	Resistor	1	60033530	2KΩ	34	Screw	4	6C520306	SP-3x6
8	Resistor	1	60033529	470Ω					
9	Transistor radiator	1	60031482						
10	Plate	1	60033536						
11	Transistor	1	60031481	BUV48A ★					
12	Diode	1	60031453						
13	Terminal	1	60031666	2P					
14	Rectifier	1	60033526	5B2					
15	Fuse holder	1	64000019						
16	Fuse	1	60031601	2A					
17	Lamp	1	60033525						
	Lamp	1	60035062	42V KE only					
	Lamp holder	1	60030746	42V KE only					
18	Terminal	1	60030656	4P					
19	Rubber bush	1	60032575						
20	Cabtyre cord	1	60031468	(5P)900					
21	Metal socket	1	6N100061						
22	Metal plug	1	6N100056						
23	Cabtyre cord (5M)	1	61004458						
	Cabtyre cord (5M)	1	61005393	KE only CE type					
24	Rubber plug	1	60030280						
26	Cabtyre cord A'ssy(3P)	1	61004264						
	Cabtyre cord A'ssy(3P)	1	61004306	For transformers					
	Cabtyre cord A'ssy(3P)	1	61004272	No plug type					
	Cabtyre cord A'ssy(3P) CE type	1	61005385	KE only No plug type					
	Cabtyre cord A'ssy(3P) CE type	1	61005386	KE only For transformers					

10.3 Tracer Head

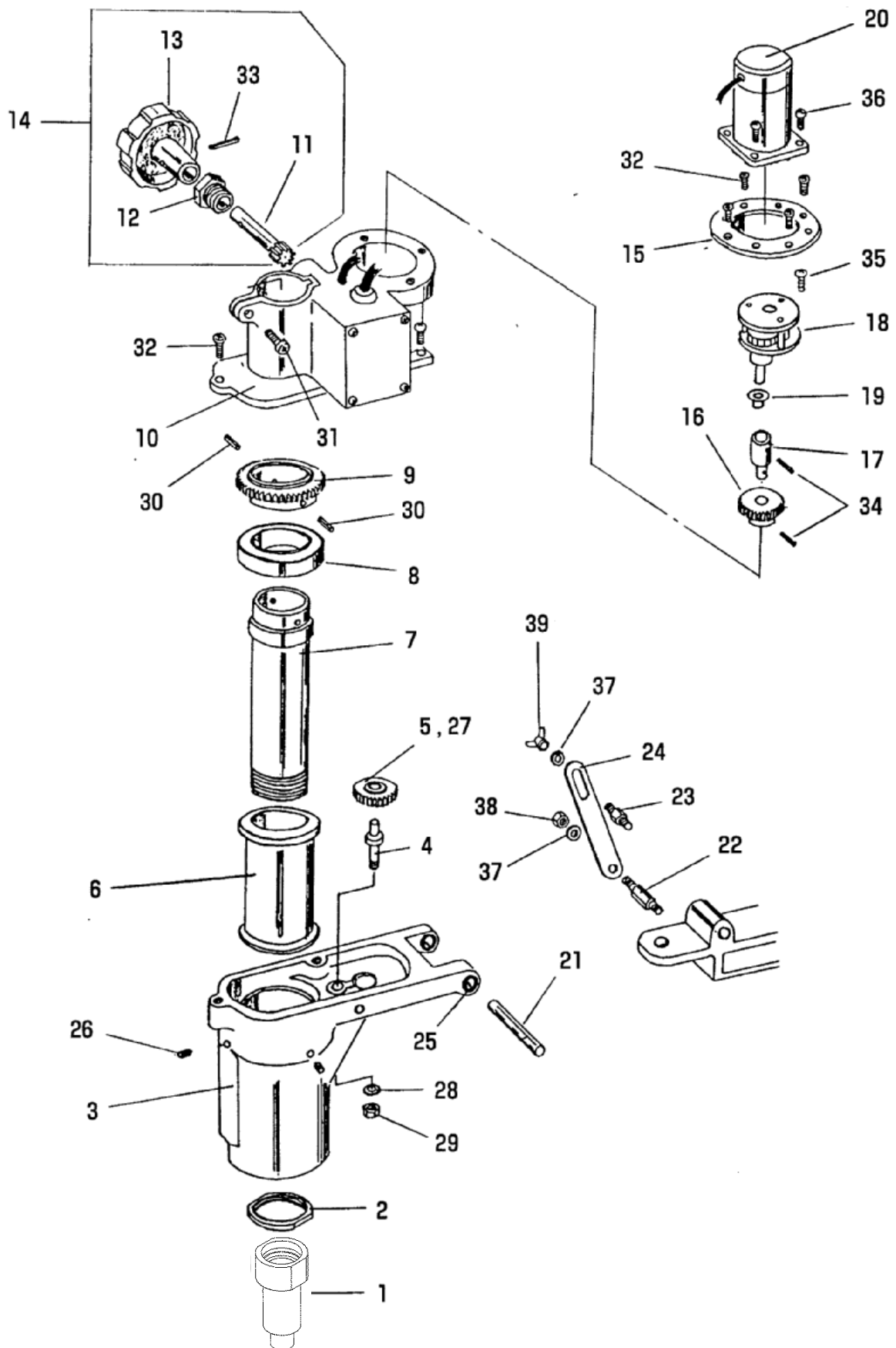

10.4 Torch

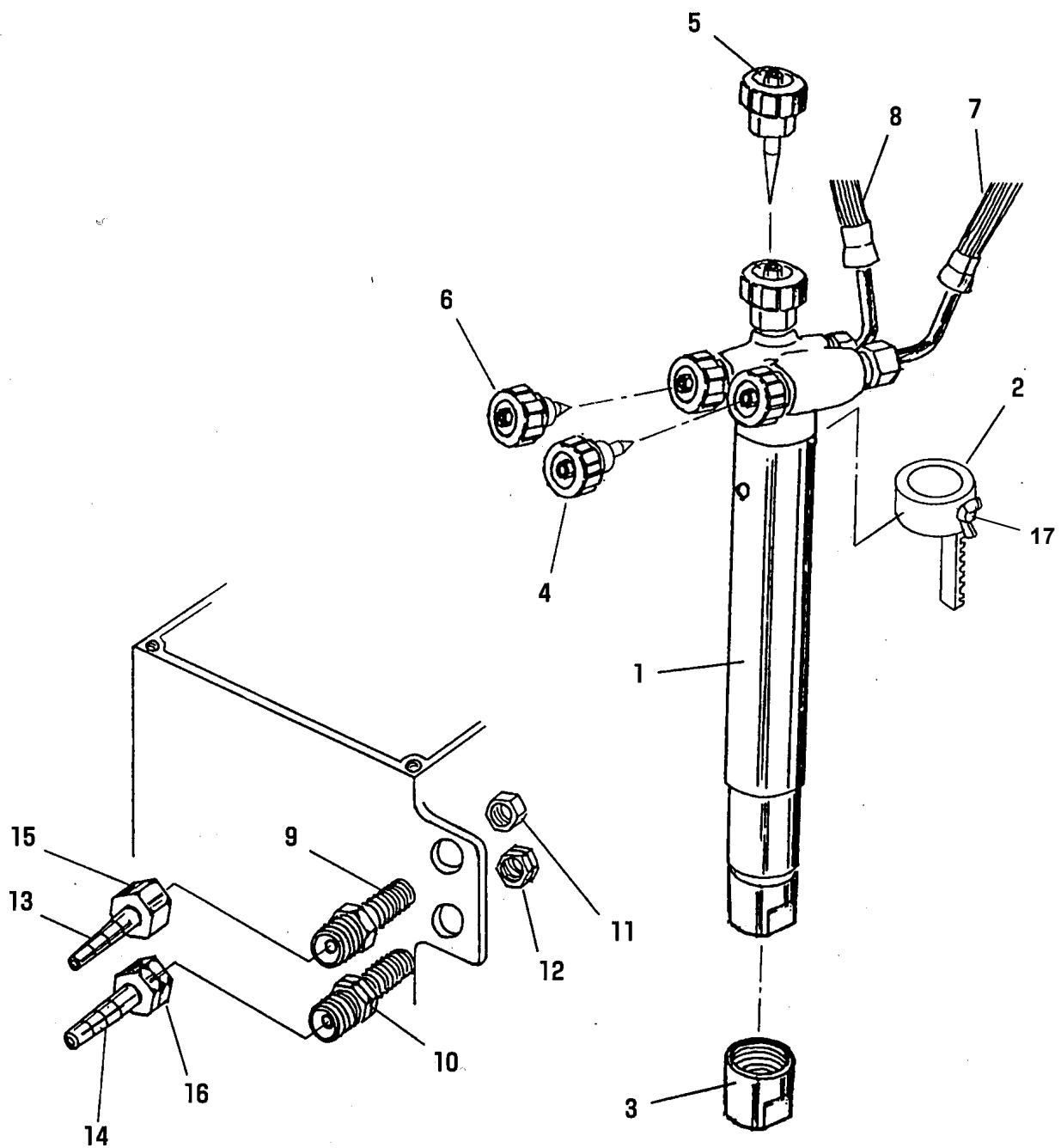

11 Cutting data

Calculate the cutting width of the tip

Tip Size	0	1	2
Cutting Width	1.0	1.2	1.4

The cutting width is 1.5-2.0 times as large as the cutting oxygen hole diameter.

402ST Type Cutting Data (Acetylene)

Tip Size No.	Plate Thickness (m/m)	Pressure(kg/cm ²) / (Mpa)		Cutting Speed (mm/min)	Quantity (ℓ/H)		
		Oxygen	Acetylene		Quantity (ℓ/H)	Quantity (ℓ/H)	Quantity (ℓ/H)
0	5~10	2.0 / 0.2	0.20 / 0.02	450~500	1,200	380	340
1	10~15	2.5 / 0.25	0.20 / 0.02	400~450	2,100	485	440
2	15~30	3.0 / 0.3	0.20 / 0.02	350~400	3,400	485	440

406NT Type Cutting Data (Propane)

Tip Size No.	Plate Thickness (m/m)	Pressure(kg/cm ²) / (Mpa)		Cutting Speed (mm/min)	Quantity (ℓ/H)		
		Oxygen	Acetylene		Quantity (ℓ/H)	Quantity (ℓ/H)	Quantity (ℓ/H)
0	5~10	2.0 / 0.2	0.2 / 0.02	450~500	1,200	1,640	410
1	10~15	2.5 / 0.25	0.2 / 0.02	400~450	2,100	1,640	410
2	15~30	3.0 / 0.3	0.2 / 0.02	350~400	3,400	1,640	410

- Note:
- 1) All Pressures are torch inlet pressures.
 - 2) Oxygen purity is minimum of 99.7%; propane is minimum of JIS Grade 3.
 - 3) Depending on the surface condition of the steel plate (scale, paint), either increase the fuel gas pressure or decrease cutting speed. Also, when precision cutting is required, adjust all data.

IK-82 M-300
(Concentrick Tracing Cutter)
OPERATION MANUAL

Date of issue: Feb.1996
: Oct.1996
: Feb.1999
: Dec.2004
: May.2006
: Sep.2006
: Jun.2007
: Aug.2008
: Mar.2009
: Jul.2010
: Dec.2010
: Jun.2011
: Mar.2012
: Dec.2012
: Feb.2013
: Jul.2013
: Nov.2015
: Jul.2016
: Oct.2018
: Mar.2019
: Sep.2019
: Jun.2020
: May.2024
: Jun .2024

KOIKE SANZO KOGYO CO., LTD

Printed in Japan