

NEW

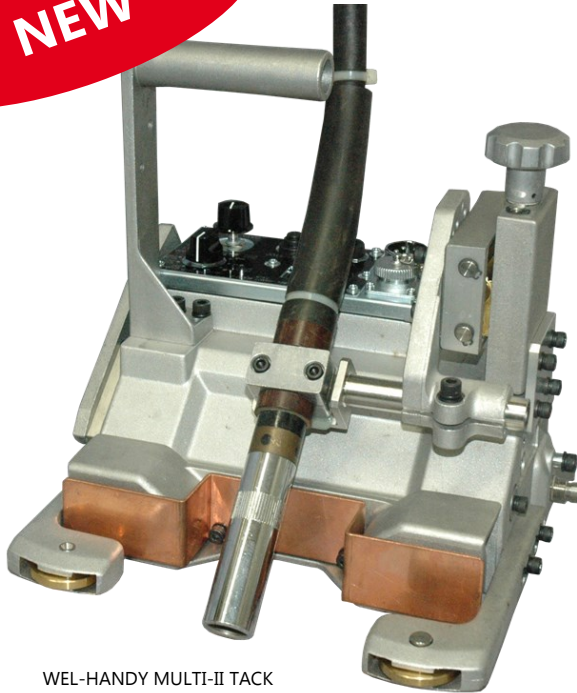

WEL-HANDY MULTI-II TACK

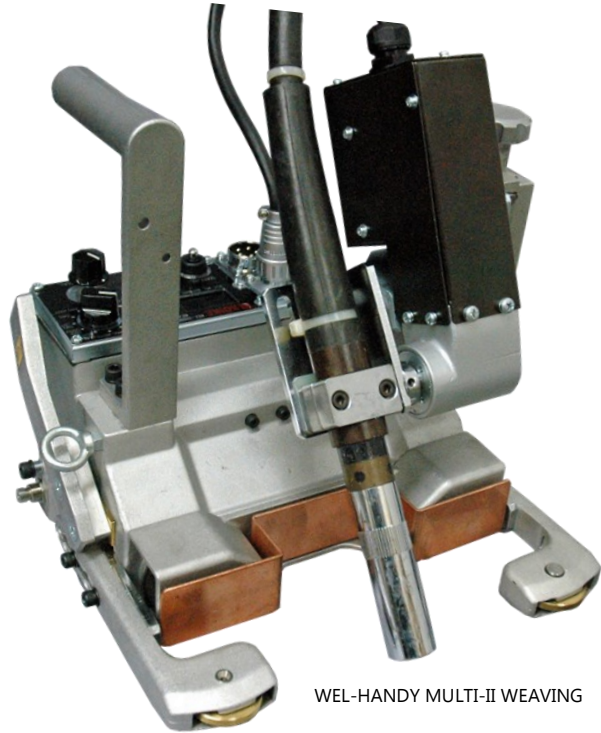

WEL-HANDY MULTI-II WEAVING

# WEL-HANDY MULTI II Series

## Heavy-Duty Multi Purpose Mechanized Welding Carriage

### Features and Benefits

- **Two models:**
  - **WEL-HANDY MULTI-II TACK:** Tack welding
  - **WEL-HANDY MULTI-II WEAVING:** Tack and Weaving welding
- **NEW - Crater fill function**  
Automatically switches to crater amperage and travel backwards to process high quality crater filling.
- **NEW - Limit switch function**  
Limit switch has dry-run function, which makes positioning of the carriage possible without lifting. (Patent pending)
- **NEW - Encoder drive motor and control**  
Ensures precise speed control during welding.
- **NEW - Weaving control (only for weaving model)**  
Weaving parameter is adjustable during welding. Easy operation with dial control.
- **NEW - Tack welding and Weaving at the same time.**
- **UNCHANGED** - Reliability, Robustness and Durability.

Light, compact, all wheel drive, magnetic force traction and a low center of gravity allows the **Wel-Handy Multi -II** to achieve the highest pulling power and stability in the marketplace today. are improved for the welder by reducing fatigue, fumes and sparks.

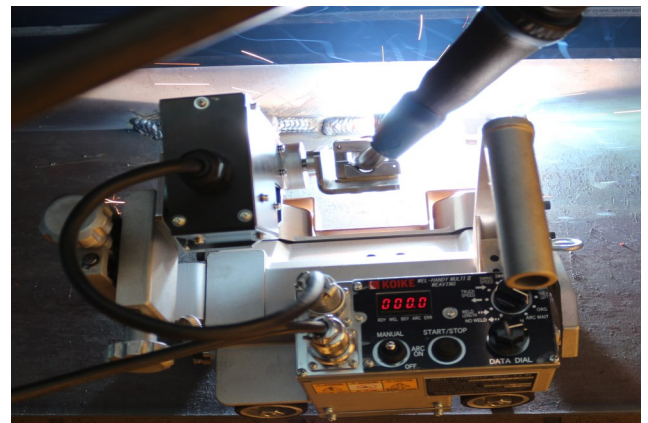



## The NEW Advanced tack controller

### Controllable tack welding distance

- Tack and dry-run distance can be controlled during welding just by simple click on a toggle switch.
- Equipped with encoder motor. WEL-HANDY MULTI - II TACK calculates travel distance by counting motor rotation, enabling accurate distance control.
- All parameter values are shown on the digital display for easier parameter management and repeatability.

**Previous model** - Tack and dry-run distances are fixed

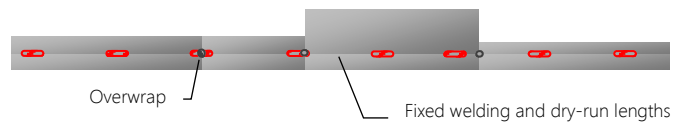

**WEL-HANDY MULTI - II TACK control** - Controllable tack distance

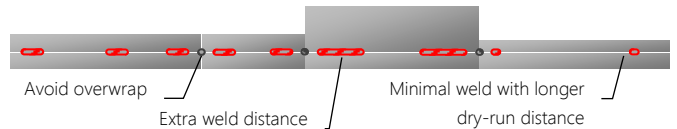

### Crater filling function<sup>(\*)</sup>

(\*) requires welding machine with crater function with matching control.

- Automatically switches to crater amperage at the end of each weld for crater fill sequence.

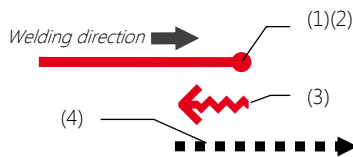

- 1) At end of each weld, carriage gives signal to welding power source to switch to crater amperage.
- 2) Carriage stops for a set period of time
- 3) With crater amperage, carriage welds backwards at a set speed for a set distance
- 4) After crater sequence, carriage dry-runs to starting point of next tack weld (in tack welding mode)

### WU-5R Weaving Unit (Option for TACK, Standard with WEAVING model)

A Option for WEL-HANDY MULTI-II TACK to perform weaving welding. Includes mounting bracket. Weaving is controlled by encoder motor.

- Weaving speed (\*): 400 - 1500 mm/min
- Weaving widths>(\*): 0 - 100.0 mm/min
- Stop timer (left/center/right): 0.0 - 10.0 seconds





## Optional Accessories



### Twin torch option

- 2 torch fillet welding
- Upto 500mm fillet height
- Lightweight aluminum arms

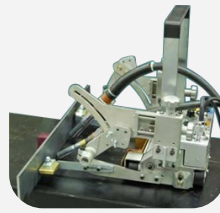

### Tandem torch option

- Productivity improvement with tandem torch.
- Fan-shaped bracket suitable for delicate torch setting loaded.

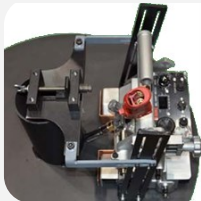

### Tubular follower guide

- Traverse by vertical guidance of curved plate using bearings on both sides of plate.
- Suitable for welding short pipes onto a plate.

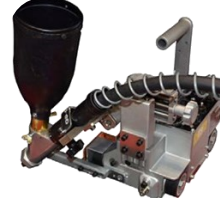

### Compact Submerged Arc option

- Makes Wel-Handy Multi an ultra compact carriage for submerged welding.
- Contact Koike for details.

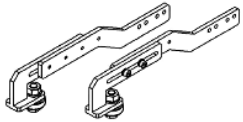

### Plate edge guide roller

- Roller adjustable by 50mm forward/backward
- Plate need to be 10mm thickness



### Magnet lifting handle

- Makes magnet release much easier

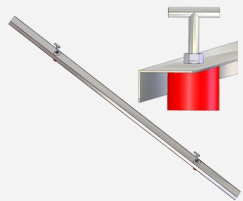

### Straight guide rail

- For butt welding in straight line.
- 2m long, 2x magnets included.



### Guide roller extension plate

- Extends guide roller by 45mm.



### Two-point torch holder (curved)

- Secures the torch tightly with 2 clamps.
- Torch compatibility need to be checked.



### Weaving Unit WU-5R

- Add to WEL-HANDY MULTI-II TACK to enable weaving welding.
- Tack and weaving can be performed simultaneously with WEL-HANDY MULTI-II controller.

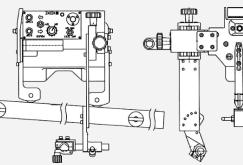

### Torch holder extension bar

- Extends the torch by 140-220mm.
- Suitable for butt welding using guide rail.









### Clamp lever

- Faster torch angle and position adjustment

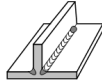
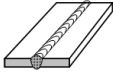
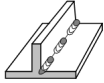
Accessory	Stock #
Twin torch option	90216
Tubular follower guide	1115-1095-00
Plate edge guide roller	T61004332
Straight guide rail	61002282
Two-point torch holder (curved)	61000865
Torch holder extension bar	T61001223

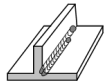
Accessory	Stock #
Tandem torch option	on request
Compact Submerged Arc option	on request
Magnet lifting handle	T61001636
Guide roller extension plate	T61002102
Weaving unit WU-5R	90255
Clamp lever	T64000044
Transformer PR 100-240V-SEC 24V 65W	222.002.256

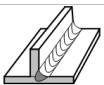
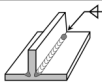
# Application guide

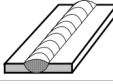
Model		TACK	TACK+WEAVING
Stock No.		90245	90246
Fillet weld		●	●
Butt weld		Guide rail option	Guide rail option
Tack / Stich weld		-	●
Vertical weld		●	●
Horizontal position		Guide rail option	Guide rail option
1 run 2 pass		Tandem torch option	Tandem torch option
Contour weld		Tubular follower guide option	Tubular follower guide option
Pendulum Oscillation		-	●
Dual pass		Twin torch option	Twin torch option
Overhanging weld		●	-
Sub-Arc		Compact SAW option	Compact SAW option

● : possible

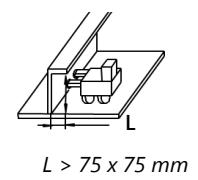
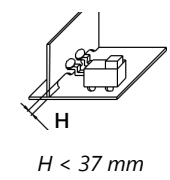
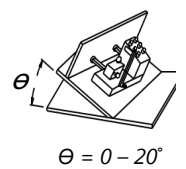
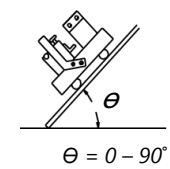
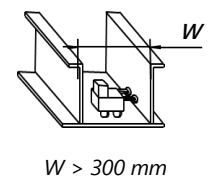
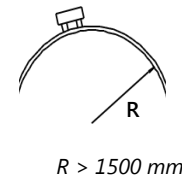
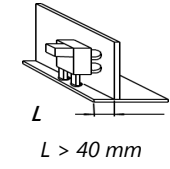
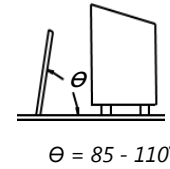
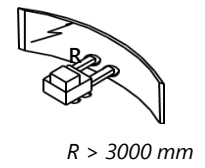
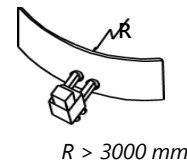

Vertical up butt welding using guide rail



Twin torch option



# Type and Specification

## Specifications

		WEL-HANDY MULTI-II TACK	WEL-HANDY MULTI-II WEAVING
Machine weight		7.5 kg	9.1 kg
Traction Force		16 kg	12 kg
Travel speed		50 ~ 1500 mm/min	
Tracking system		Fillet tracking guide roller	
Standoff (plate to base plate)		6 mm	
Magnet up/down mechanism		Magnet release lever	
Driving method		4-wheel Driving Rubber Roller (Chain Transmission)	
Magnet type		50 kg Permanent Magnet	
Torch adjustment	Torch angle	40 ~ 55°	
	Up/down	45 mm	
	Forward/backward	45 mm	
Torch holder diameter		16 ~ 20 mm	
Automatic stop function		Limit switch on each end of carriage	
Unwelded lengths (start & end total)		approx. 270 mm	approx. 305 mm
Weaving unit		-	included
Welding method	Continuous	Yes	Yes
	Tack / Stitch	Yes	Yes
	Weaving / Oscillation	Optional	Standard
Power & signal cable		Power and Signal integrated Y-branch cable (Carriage-branch: 6 m, Branch-Power: 10 m, Branch-feeder:0.5 m)	
Torch holder diameter		16 ~ 20 mm	
Position adjustment by limit switch		Yes	
Encoder motor for precise speed control		Yes	
Digital display		Yes	
Crater fill function		Yes	
Input power		DC 24V	

## Types

Carriage Model		Stock #
WEL-HANDY MULTI-II TACK	DC24V	90245
WEL-HANDY MULTI-II WEAVING	DC24V	90246

Dimension: WEL-HANDY MULTI-II TACK

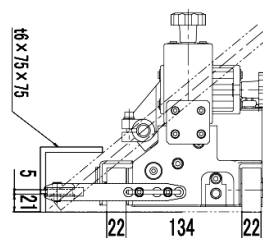
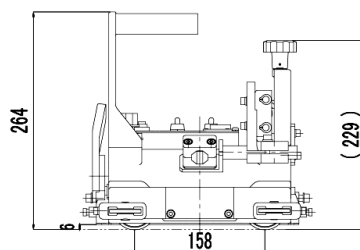
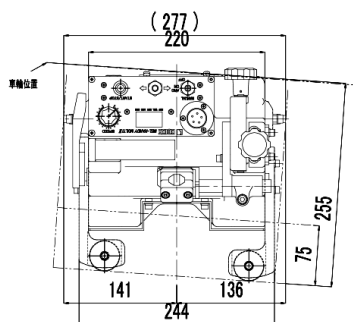

## Scope of delivery

Scope of delivery
Machine body
Weaving unit (WEAVING model only)
Power & signal cable
Allen keys (2pcs)
Operation manual

## EMEA Sales and Service Offices

### FRANCE

KOIKE France S.A.R.L.  
ZAC de la Vallee de L'aunelle  
RN Cellules C1 à C4  
59144 Wagnies-Le-Grand  
Office: +33 327304343

### GERMANY

KOIKE EUROPE B.V. Germany Branch Office  
Im Löchel 2  
35423 Lich-Eberstadt  
Office: +49 6004916930

### ITALY

KOIKE ITALIA Srl  
Via Papa Giovanni XXIII, n 45  
20053 - Rodano (Milano)  
Office: +39 0295328717

### UAE

KOIKE MIDDLE EAST FZE  
SAIF Zone Sharjah - UAE  
P.O. Box 122978  
Office: +971 561177615

### THE NETHERLANDS

KOIKE EUROPE B.V.  
Grote Tocht 19  
1507 CG Zaandam

T +31 (0)75 612 72 27  
F +31 (0)75 612 34 61

[info@koike-europe.com](mailto:info@koike-europe.com)  
[www.koike-europe.com](http://www.koike-europe.com)