

CNC Plasma Cutting Machine

# FLEXIGRAPH-1530



## Table Integrated Plasma Cutting Machine

with a range of cutting width 1,550mm and length 3,050mm

- ❖ Dual sides drive machine body and LM guide rail for both axes, longitudinal/transverse, ensure high quality cutting with smooth machine movement.
- ❖ Compact CNC KOIKE D470, but powerful functions .
- ❖ Various type of plasma cutting systems can be mounted.
- ❖ Easy installation, required only for leveling.



**KOIKE SANZO KOGYO CO., LTD.**

International Division

1-9-3, Onodai, Midori-ku, Chiba-shi, Chiba, 267-0056 Japan

Tel: +81-43-239-2130

Fax: +81-43-239-2129

<http://www.koike-asia.com>

## Machine Drawing

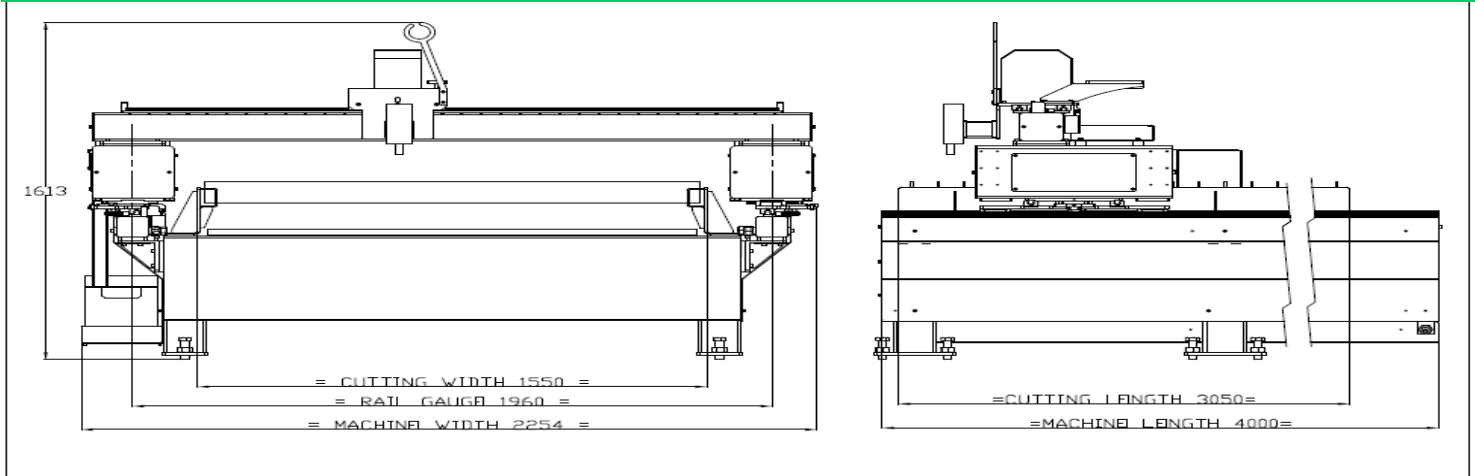

## Optional Plasma System

Power source	Kjellberg Cut Fire 100i	HYPER THERM PMX105
Primary Power supply	3X400V, 50 Hz	3X400V, 50 Hz
Output Current	20-100 A	30-105 A
Cutting Range Maximum Recommended	20 mm 10-12 mm	20 mm 12 mm
Dimension (L x B x H) [mm]	710 x 280 x 590	592 x 274 x 508
Weight	50 kg	50 kg
Power Source capacity	16.6 KVA	16.8KVA



## Specification of FLEXIGRAPH-1530DD

Machine type	Air Plasma Ready Type
Main body	Dual-side Drive
Effective Cutting width	1,550 mm
Effective Cutting Length	3,050 mm
Drive Method	Rack & Pinion drive for X and Y axes
Servo Drive	Panasonic AC servo drive
Cutting Speed	Maximum 6 m/min
Rapid Traverse Speed	12 m/min
CNC System	KOIKE D470
Cutting Capacity	Depend on plasma cutting system
Plasma Torch Height Con-	AVC type, Model HP-103
Plasma Torch Holder	De-coupler type with initial height sensing
Machine Color	Koike Red ( Main body) Black (Cutting table)

## Specification of Controller

Model	D 470
Screen size	15" High Brightness Color LCD.
Control Accuracy	+/- 0.001mm
Working Temperature	0-50 degree Celsius
Relative Humidity	5-95 %
No. of shapes	47
Key Board	PCB foiled keyboard
Program	NC Program EIA format
USB	Interface at least 12 GB disk supportable



**KOIKE SANSO KOGYO CO., LTD. International Division**  
**THE MOST COMPLETE LINE IN THE INDUSTRY**

### Singapore / Malaysia / Indonesia

Regional Marketing Manager : James LIM S.G.  
 Email address : jameslimsg@hotmail.com  
 Tel : +65-9634-6048  
 Fax : +65-6443-4058

### Thailand

Marketing Manager : Sumedh Kongsiriwong  
 Email address : Gengsumedh@hotmail.com  
 Tel : +66-1511-5445  
 Fax : +66-2612-1986

### Vietnam

Marketing Manager : Nguyen Kim LAM  
 Email address : nguyenkilam2004@yahoo.co.uk  
 Tel : +84-9-1357-4813  
 Fax : +84-4-633-6958

### Philippines

Marketing Manager : Grace Mendoza  
 Email address : gryze\_mendoza@yahoo.com  
 Tel : +63-917-861-0880  
 Fax : +63-46-543-2003