

Portable Automatic Gas Cutter



BEA00B24

IK-54D

Pattern Cutter

OPERATION MANUAL



For every person who will be engaged in operation and maintenance supervision, It is recommended to read through this manual before any operations, so as to permit optimum operation of this machine.

KOIKE SANZO KOGYO CO.,LTD.

INTRODUCTION

Thank you very much for purchasing this product. Read this instruction manual thoroughly to ensure correct, safe and effective use of the machine. Read the manual first to understand how to operate and maintain the machine. Cooperation between colleagues in the workplace is essential for safe, smooth operation. Make sure you read, understand and take all necessary safety precautions.

SAFETY PRECAUTIONS









This product is designed to be safe, but it can cause serious accidents if not operated correctly. Those who operate and repair this machine must read this manual thoroughly before operating, inspecting and maintaining the machine. Keep the manual near the machine so that anyone operates the machine can refer to it as necessary.

- Do not use the machine carelessly without following the instructions in the manual.
- Use the machine only after you have completely understood the contents of the manual.
- If an explanation in the manual is difficult to understand, contact our company or sales service office.
- Keep the manual to hand at all times and read it as many times as is necessary for a complete understanding.
- If the manual becomes lost or damaged, place an order with our company or sales service office for a new one.
- When transferring the machine to a new owner, be sure to hand over this instruction manual as well.

QUALIFICATIONS FOR MACHINE OPERATOR

Operators and repair staff of this machine must completely understand the contents of the instruction manual and have either of the following qualifications:

1. Gas welding foremen's license
2. Completion of gas welding training course
3. Approval by the Minister of Labor

Symbol	Title	Meaning
	General	General caution, warning, and danger.
	Be careful not to get your fingers caught.	Possible injury to fingers if caught in the insertion port.
	Caution: Electric shock!	Possible electric shock under special conditions.
	Ground this equipment.	Operators must ground the equipment using the safety grounding terminal.
	Pull out the power plug from the outlet.	Operators must unplug the power plug from the outlet when a failure occurs or when there is a danger of lightning damage.
	Caution against bursting	Possible bursting under certain conditions.
	General	General warning.
	Caution: Hot!	Possible injury due to high temperature under certain conditions.
	Caution: Ignition!	Possible ignition under certain conditions.

CONTENTS

1. Safety Information -----	1
1.1 General machine safety precautions -----	1
1.2 Gas cutting safety precautions -----	3
2. Locations of safety labels -----	5
3. Outline of machine -----	6
3.1 Features of machine -----	6
3.2 Name and function of each section -----	6
3.3 Specifications -----	7
4. Preparation for operation -----	8
4.1 Contents of package -----	8
4.2 Machine assembly -----	9
4.3 Preparation for operation -----	9
5. Cutting operation -----	13
5.1 Safety measures prior to operation -----	13
5.2 Ignition and flame adjustment -----	13
5.3 Cutting and piercing method -----	14
5.4 Procedure for starting cutting and the method of extinguishing fire (pattern cutting) ----	14
5.5 Cutting operation -----	15
5.6 Option -----	15
6. Maintenance and inspection -----	16
6.1 Daily inspection -----	16
6.2 Monthly inspection -----	16
6.3 3-month inspection -----	16
7. Trouble shooting -----	17
8. Wiring diagram -----	18
9. Assembly drawing of IK-54D -----	18
10. Parts list -----	19
10.1 Gear case, No.1 arm unit -----	19
10.2 Upper arm, Main spindle, unit -----	21
10.3 No.2 arm, weight unit -----	23
11. Cutting data -----	25

1 Safety information

Many accidents are caused by operation, inspection, and maintenance which disregard the basic safety rules. Carefully read, understand, and master the safety measures and precautions described in this instruction manual and on the machine before operating, inspecting, and maintaining the machine.

The safety messages are classified as indicated on the machine safety labels:

■ **WARNING**

This word is used in a warning message and a warning label is positioned at places that could cause injury or serious accident.

■ **CAUTION**

This word is used in a caution message and a caution label is positioned at places that could cause slight injury or machine damage. This is also used as a caution for frequent dangerous actions.

■ **NOTICE SIGNS**

This is a sign to show machine operators and maintenance engineers items that relate directly to damage of machines and surrounding facilities and equipment.

1.1 General machine safety precautions

Read and fully understand the following important safety information:

1.1.1 Machine safety

- 1.The machine casing is mainly made of aluminum alloy to reduce weight. For this reason, be careful not to drop a heavy item on the machine, or not drop the machine when carrying it, since the alloy is not designed to withstand such impact.
- 2.When mounting hoses to the torch and distributor, tighten the nut with the attached wrench. After mounting, be sure to check there is no gas leak with a detection liquid. If a gas leak is found, retighten the nut firmly.
- 3.When fixing a tip to the torch, tighten the nut with the two wrenches attached. In addition, avoid damaging the taper part of the tip since this may cause backfire.
- 4.Never disassemble the machine other than during maintenance and inspection. Otherwise, malfunction will result.
- 5.Never remodel the machine. Remodeling is very dangerous.
- 6.When changing the direction, make sure that the direction switch is in the neutral(stop)position, and operate the direction switch after the machine has stopped.
7. Always turn the power off when not in use.
8. Never use the machine outdoors when the weather is wet. This will cause failure of the machine and could cause a fatal accident by electric shock.

1.1.2 Safety clothing

- 1.Be sure to wear protector's gauntlets, goggles, helmet, and safety shoes during operation.
- 2.Avoid operating the machine with wet clothes or hands in order to prevent electric shock.

1.1.3 Operation and handling safety precautions

1. Read this instruction manual before operating the machine.
2. Mount and center the machine correctly and confirm correct motion before operation.
3. Before connecting the power plug to the outlet, make sure that the power switch is in the OFF position (or the normal/reverse changeover switch is in the stop position).
4. Prior to operating the machine, check the safety of the surroundings to avoid accidents.
5. Never move the machine while the preheat flame is on.
6. Take great care of spatters and dross when operating the machine at a high position. They may injure people below.
7. Firmly secure the balance weight.
8. Secure the upper and No.2 arms with a curved handle so that they will not fall off the shaft.
9. Secure the upper, No.1, and No.2 arms when carrying the machine. Exercise special care when carrying the machine.

1.1.4 Electrical system precautions



1. Be sure to check the input power voltage of the machine before operation. The input power voltage should be in the range of $\pm 10\%$ of the rated voltage. The machine should not be operated out of this range.
2. The metal plugs are screw-threaded, therefore, fully tighten them so that they will not come loose during operation.
3. The ground pin is attached to the rubber plug of a cable cord. Please use a power receptacle with a ground pin opening
4. **Stop operation and turn off the power in the following cases, and ask a qualified electrician to repair the machine.**

 - 1) Broken or abraded cables
 - 2) When the machine has been in contact with water, or in case of liquid damage to the machine
 - 3) Abnormal machine operation despite operating the machine according to the instruction manual
 - 4) Machine breakdown
 - 5) Poor machine performance that requires repair
5. Periodically inspect the electrical system

1.1.5 Maintenance and inspection precautions



1. Ask a qualified electrician to perform repair and inspection service.
2. Disconnect the power plug before inspecting and repairing the machine.
3. Maintain the machine periodically.

1.2 Gas cutting safety precautions

Strictly observe the safety rules and precautions to ensure the safety of gas cutting operations. Operators and supervisors MUST keep safety in mind.

1.2.1 Prevention of explosion



1. Never cut pressurized cylinders or hermetically sealed containers.
2. Ensure sufficient ventilation for gas cutting to prevent the air from becoming stale.

1.2.2 Pressure regulator safety precautions



1. Before starting operation, check that all pressure regulators are operating correctly.
2. Ask a skilled repair engineer to perform maintenance and inspection service.
3. Do not use pressure regulators from which gas is leaking, nor malfunctioning pressure regulators.
4. Do not use pressure regulators smeared with oil or grease.

1.2.3 High Pressure gas cylinder safety precautions



1. Never use broken cylinders or cylinders from which gas are leaking.
2. Install cylinders upright and take measures to prevent them from falling.
3. Use cylinders only for specified purposes.
4. Do not smear container valves with oil or grease.
5. Install cylinders in a place free from heat, sparks, slag, and open flame.
6. Contact the distributor if the container valves will not open.
Never use a hammer, wrench, or other tools to forcibly open container valves.

1.2.4 Safety precautions for hoses



1. Use the oxygen hose for oxygen gas only.
2. Replace cracked hoses or other hoses damaged by sparks, heat, unshielded fire, etc.
3. Install hoses without twisting.
4. To prevent breakage of hoses, take great care during operation and transportation.
5. Do not hold the hoses when moving the machine.
6. Periodically check the hoses for damage, leakage, fatigue, loose joints, etc, to ensure safety.
7. Cut hoses to the minimum possible length. Short hoses reduce hose damage and pressure drop, as well as reduce the flow resistance.

1.2.5 Safety precautions for fire



Take safety precautions to prevent fire prior to gas cutting. Ignoring hot metal, sparks, and slag could cause a fire.

1. Keep a fire extinguisher, fire extinguish sand, bucket full of water, etc. ready on the site where gas cutting is performed.
2. Keep flammables away from the cutting area to avoid exposure to sparks.
3. Always cool down steel plates that have become hot after cutting, as well as hot cut parts or scrap, before bringing them close to flammables.
4. Never cut containers to which flammable materials are stuck.

1.2.6 Safety precautions for skin burns



Observe the safety precautions to prevent skin burns. Ignoring heat, spatter, and sparks during operation could cause a fire or burned skin.

1. Do not perform cutting near flammables. (Move flammables well away from the sparks.)
2. Do not cut containers filled with flammables.
3. Do not keep lighters, matches, and other flammables nearby.
4. Flames from the torch will burn the skin. Keep your body away from the torch and tip, and check the safety before operating the switches and valves.
5. Wear the correct protectors to protect your eyes and body.
6. Correctly tighten the tip to prevent backfire.
 - When fixing a tip to the torch, tighten the nut with the two wrenches attached.
 - If the tip is tightened excessively, it will be heated during cutting and tightened still more, making it difficult to remove the tip.
 - Avoid damaging the taper of the tip since this may cause backfire.
7. Check with soapsuds for any leakage of gas from the connection part of the distributor, hose and torch. Never use oil or grease on the connection of the oxygen pipe to avoid backfire which may lead to explosion.
8. Be sure to check the following when igniting:
 - Place the torch on the torch holder before igniting.
 - Always wear the required protectors (gauntlets, helmet, goggles, etc.)
 - Check for any obstacles, dangerous materials and flammables near or in the direction of cutting. Determine the gas pressure.
 - The gas pressure must be within the appropriate range. (For the gas pressure, refer to the Cutting Data.)
9. The torch, tip and heat shield are heated to a very high temperature. Always wear gauntlets when handling them. Also the surface after cutting is very hot so do not touch it even while wearing gauntlets.
10. Never move the machine while the preheat flame is on.

2 Locations of safety labels

Safety labels and other labels for correct operation are affixed to the machine.
 Carefully read the labels and follow the instructions on them when operating the machine.
 Never remove the labels. Keep them clean and legible at all times.

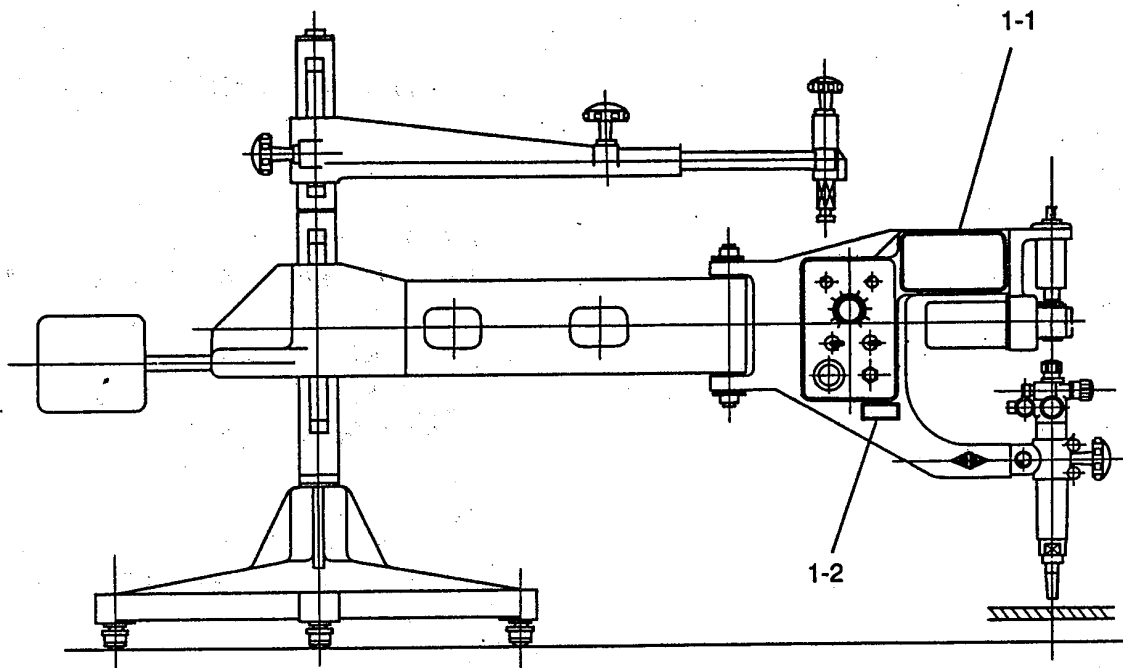

IK-54D	
AUTOMATIC GAS CUTTING MACHINE	
CUTTING CAPACITY	<input type="text" value="3"/> ~ <input type="text" value="100"/> mm
CUTTING SPEED	<input type="text" value="100"/> ~ <input type="text" value="1000"/> mm/min
INPUT SINGLE PHASE AC	<input type="text"/> V
SERIAL NO.	<input type="text"/>
KOIKE SANSO KOGYO CO., LTD.	
MADE IN JAPAN	

NET WEIGHT	<input type="text"/>	Kg
------------	----------------------	----

1-2

1-1

3 Outline of machine

3.1 Features of machine

The IK-54D is equipped with the following 8 features.

1. The machine is stable.

The fixed type main shaft ensures stability of the machine.

2. The cutting range has been further enlarged.

The arm turns 360 degrees around the main spindle. Put a tracing pattern is on the main shaft, and cutting operation up to 1,700 dia. is possible.

3. The traveling speed range has been widened to improve the traveling performance.

A DC shunt motor is used for driving, and the PWM control system has been adopted for wider speed change range and stabler traveling speed.

4. The tip and torch can be changed easily.

A rotary torch holder is adopted, and the high-accuracy stability has been ensured by a special pin. Therefore torch change and tip cleaning are very easy.

5. Distinguished operability

Operation switches are collected in the No.1 arm section for very easy operation.

6. Several types of magnets can be attached.

In addition to the standard 10 dia. magnet roller, 6, 8, 15 and 20 dia, magnet rollers are provided. They can be changed easily. These strong magnets ensure stable tracing.

7. Lightweight stand

A light alloy is used for reduction in weight

8. A pattern is unnecessary for circle cutting.

Use of circle cutting attachment (option) permits cutting 60-400 dia. circles without a pattern.

3.2 Name and function of each section

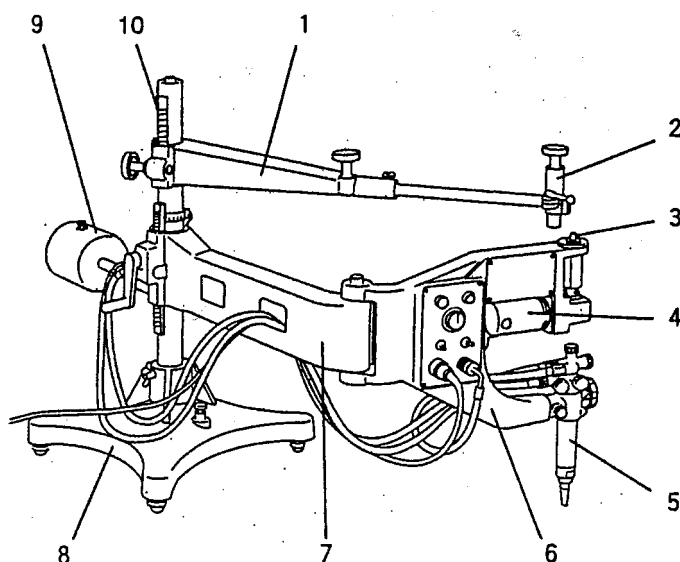

1. Upper arm

Used for setting the cutting direction.

2. Template holder

Used for attaching a tracing pattern.

3. Magnet roller

Turns along a tracing pattern.

4. Motor

5. Torch

6. No.1 arm

7. No2 arm

8. Stand

9. Weight

10. Main spindle

3.3 Specifications

Weight:	33kg (without weight)
Machine size:	1,260×695×550mm
Power:	±10%
Motor:	DC 23W
Speed control :	PWM control system
Cutting thickness:	3 - 100 mm
Cutting speed:	100-1,000 mm/min
Cutting accuracy:	with in ± 0.5 at $\phi 500$ mm
Magnet roller:	$\phi 10$
Cutting range:	
for circle	$\phi 30 \sim \phi 700$
for circle (when main spindle rotate)	$\phi 600 \sim \phi 1,700$
for square	$\square 30 \sim \square 600$
for square (when main spindle rotate)	$\square 500 \sim \square 1,200$
Tip:	102 (for acetylene) or 106 (for propane)
Gas:	Oxygen, acetylene gas, or LPG gas

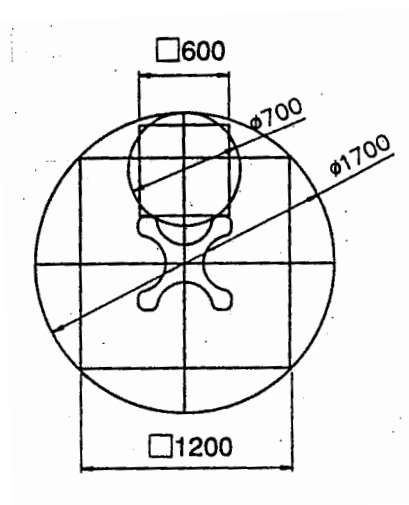

●Accessories

Tip 102 (for acetylene) or 106 (for propane) # 0,1,2	1 pc each
Power cable	1 set
Tip cleaner:	1 set
Bush	1 set
Spanner	1 pc
Center:	1 set
Ruler	1 pc
Fuse (1A)	2 pcs
Hexagon wrench M6	1 pc

●Option

Magnet roller	$\phi 6, \phi 8, \phi 15, \phi 20$
Template set plate (used for setting template to main spindle)	
Circle cutting unit	

4 Preparation for operation

4.1 Contents of package

The contents of the standard package are shown below. Check them carefully before assembling the machine.

- Stand 1set
- Main spindle 1set
- No.2 arm:..... 1set
- No.1 arm:..... 1set
- Operation panel:..... 1set
- Tracing drive unit
(motor, reduction gear, magnet roller):..... 1set
- Torch unit (torch, torch holder):..... 1set
- Upper arm (slide bar):..... 1set
- Template holder (template set bolt):..... 1set
- Weight (weight bar): 1set
- Power cable (3Px5M): 1set
- Tip 102(for acetylene) or 106 (for propane) #0,1,2: 1pc each
- Tip cleaner: 1set
- Brush: 1pc
- Spanner:..... 1pc
- Center: 1pc
- Ruler: 1pc
- Fuse: 2pcs
- Hexagon wrench M6:..... 1pc

4.2 Machine assembly

- IK-54D is packed in three corrugated cardboard boxes. Open the respective boxes and take out the parts.
 - IK-54D machine1 pack
 - IK-54D stand1 pack
 - IK-54D weight1 pack
- Place the stand (1) on a flat floor, and insert the main spindle (2) into the stand.
- Insert the No.1 and No.2 arms into the main spindle (2).
Note: Fold the No.1 and No.2 arms and then insert them.
- Insert the weight bar (5) into the hole in the No.2 arm, attach the weight (6), extend the arm, and secure it in an appropriate position with a bolt so that the arm will be well balanced.
- Insert the upper arm (7) into the main spindle (2).
- Insert the torch (8) into the torch holder (9).
- Connect the hose (10) with the pressure switch (11)
- Put the hoses (12) and (13) through under the arm to connect them with the torch.
- Like the hoses (12) and (13), connect the power cable (14) with the metal receptacle.
- Firmly tighten respective screws.

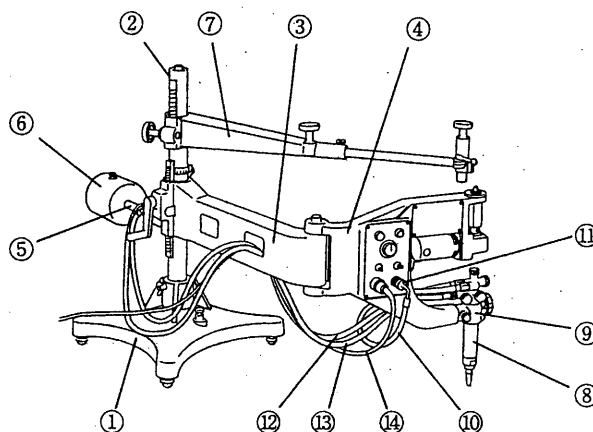

4.3 Preparation for operation



4.3.1 Connecting the power cable

- Connect the power cable to the body.
- Before plugging the metal plug on the cable side into the socket on the machine side, check there is no dust inside.
- The metal plugs are screw-threaded, therefore, fully tighten them so that they will not come loose during operation.

4.3.2 Connecting the gas supply hose

- Connect the respective gas supply hoses to the primary hose.
- Securely tighten the joints and check there is no gas leak.

4.3.3 Connecting the tip

- Select a proper tip according to the thickness of the steel plate and attach it to the torch.
(To select a tip, refer to the table of cutting data.)
 - When fixing a tip to the torch, tighten the nut with the two wrenches attached.
 - If the tip is tightened excessively, it will be heated during cutting and tightened still more, making it difficult to remove the tip.
 - In addition, avoid damaging the taper of the tip since this may cause backfire.

4.3.4 Operation method

1. Method of electrical operation

Cutting operation is controlled by the switches and speed setting knob incorporated in the operation panel of the No.1 arm. The layout of the electrical operation unit is shown below.

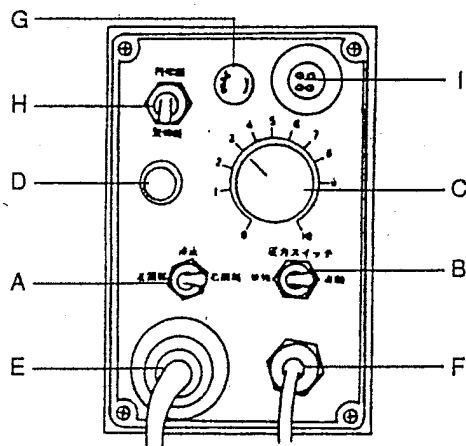

A. Drive switch.....Left/Stop/Right

Three-position switch. When the switch is in the center, the motor stops, and when it is on the left side, the motor runs for counterclockwise turning. Set it in the right position for clockwise turning. (Set the pressure switch in the "individual" position.)

B. Pressure switchIndividual/interlock

Two-position switch. Set it in the "interlock" position to operate the pressure switch, and when the cutting oxygen is emitted from the torch, the motor turns (when the drive switch is in either right or left position). When it is set in the "individual" position, the pressure switch will not operate, and the motor can be turned ON or OFF by the drive switch alone.

C. Speed setting dial

The dial with a 0-10 scale is used for setting the drive motor speed. The scale 1 corresponds to approx. 100 mm/min (for the 10-dia. magnet roller) and the scale 2 corresponds to approx. 200 mm/min.

D. Pilot lamp

When the power cable connector is connected, the pilot lamp will come on, indicating that the power is on.

E. Connector

Power connector

F. Oxygen hose end connection

For pressure switch

G. Fuse

1A

H. Change over switch for snape / Circle cutting

I. Connector

Circle cutting motor

4.3.5 Manufacture of tracing template

The magnet roller center and the torch center are concentric. The radius of the roller and the cutting width of the tip must be taken into consideration when making a tracing template. Make a tracing template based on the following:

- As shown in the figure, the cut product and template are similar to each other, but not the same. The template becomes smaller in proportion to the roller diameter, and it becomes larger in inverse proportion to the cutting width of the tip.

Mold correction table					
Tip No.	# 1	# 2	# 3	# 4	
Cutting oxygen hole dia.	1.2 mm	1.4 mm	1.6 mm	1.8 mm	
Cutting width (dia.)	1.8 mm	2.1 mm	2.4 mm	2.7 mm	
Mold correction dimension (one side)	4.1 mm	3.95 mm	3.8 mm	3.65 mm	Roller dia ϕ 10

- Outer tracing (When tracing the outside of the tracing pattern)

The value from which the correction value has been subtracted is the dimension of the tracing template.

- Inner tracing (When tracing the inside of the tracing template)

The value to which the correction value has been added is the dimension of the tracing template.

(Example)

When cutting a 100-dia. work with a tip #1 by the outer tracing method:

The template dimension: $100 - 4.1 \times 2$ (both sides) = 91.8 dia.

When the product dia. is 100, use a template of 4.1 mm-inside type.

When cutting a 100-dia. work with a tip #1 by the inner tracing method:

The template (hole) dimension: $100 + 4.1 \times 2 = 108.2$ dia.

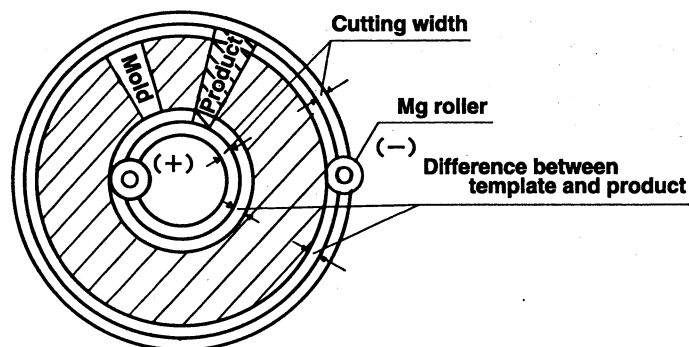

2. The template thickness shall be 3 mm or more. It shall be 6 mm or more when especially detailed cutting is necessary.

As the template becomes thicker, the magnetism becomes stronger, permitting smoother movement; therefore, use as thick a template as possible.

3. When acute-angle cutting needs high accuracy, simple finishing and machining after cutting as shown below is recommended.

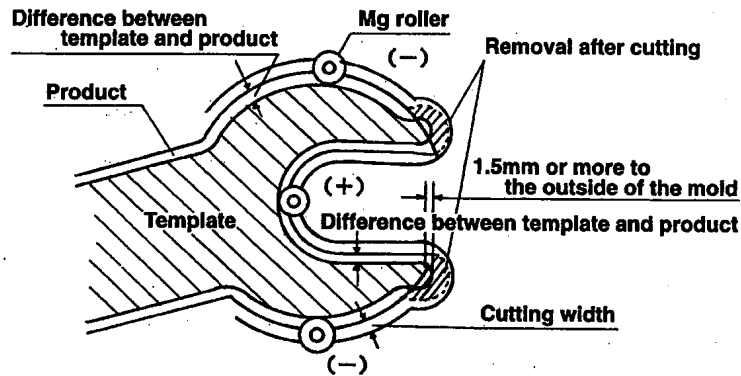

4. The bolt used to fix the template is M12. Make a hole at the center of gravity of the template.

4.3.6 Template positioning and alignment

When the cut piece is necessary, cut the steel sheet from its end to minimize scraps. However, when the remaining steel sheet is required after cutting, the template positioning is very important, and sufficient practice is necessary. Skill is especially important when cutting the same holes in specified positions.

1. When cutting a circle, make a small hole at a location 5 mm or more to the inside from the circumference for easier and quicker cutting.

(Make a hole with a drill or by piercing with the cutting tip.)

Place the center exactly on the steel sheet. Lift the template and then lower it so that the end of the magnet roller will be inserted into the template mounting bolt hole, and the center of the template will be aligned with the center of the tip. Under such conditions, move the template back and forth or turn the template holding arch clockwise and counterclockwise so that the center of the tip will be placed at the location of the center on the steel sheet. Now a correct circle can be cut in the concentric position. Affix the attached center rest to the tip for easier operation.

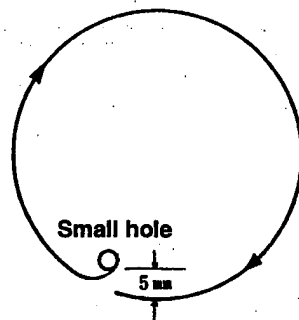

2. When cutting an irregular curve, alignment of the center of the pattern and that of the template is the first step for centering. When the curved line includes a straight section, place the template in parallel with that section while checking the position from above the template, and centering and alignment will be completed instantly. When the curve does not include any straight line, mark the center and axis in the cutting section, and make a straight slit in parallel with the axis in advance on the template. After centering, determine the direction by placing the line observed through the slit in parallel with the axis. Firmly fix the template arm to the spindle to complete the positioning and centering.

5 Cutting operation



5.1 Safety measures prior to operation

5.1.1 Grounding the machine



The cable of this machine is equipped with a grounding wire. For safety, be sure to ground the wire as follows, in addition to checking the connection of the power cable.

■ Method to ground the machine

- The ground pin is attached to the rubber plug of a cable cord. Please use a power receptacle with a ground pin opening.

5.1.2 Selection of tip

Referring to the Cutting Data, select the suitable tip according to the plate thickness.

For a heavily rusted plate or for a bevel cutting angle of more than 20°, select the tip one grade higher than the one shown in the Cutting Data.

5.1.3 Operation of running direction changeover switch



- By changing the direction switch, the machine can move forward and backward. The neutral position on the switch is the stop position of the machine.
- When changing the direction, make sure that the direction switch is in the neutral (stop) position, and operate the direction switch after the machine has stopped.
- Be sure that the switch is in the neutral position before starting the machine.
- Make sure that the switch is in the neutral position before turning the power on. If the switch is in the forward or backward position, the machine will start as soon as the power is turned on, which could cause serious accidents.
- Never put your hands in the space between the guide roller and rail, as well as between the body and the rail, while the machine is running, otherwise, your hands may be caught.

5.2 Ignition and flame adjustment

- Adjust the gas pressure according to the Cutting Data. The data shows the pressure when all the valves are open. Readjust the pressure after ignition.

■ Flame adjustment method

1. Open the fuel gas valve 1/4 to 1/2 a turn, and light the torch with an igniter.
2. Then, open the preheating oxygen valve gradually until a white cone of the standard flame has been obtained. (The incandescent area should be uniform and about 5-6 mm (3/16-1/14") in length.)
3. Open the jet oxygen valve fully. Readjust the flame if its condition has changed. A disorderly flow of the jet oxygen will adversely affect the quality of the cutting surface. In such a case, clean the tip with a suitable cleaning needle while the jet oxygen is flowing.
4. Appropriate distance between the tip end and cutting surface:
 - Acetylene gas8-10 mm
 - LPG gas5-8 mm

5. Neutral flame ensures good quality cut surfaces. (Oxygen flame may be used for bevel cutting.) Oxygen flame causes short cutting-oxygen current, allowing slugs to adhere, melting the upper edge of the cutting surface, and causing other adverse effects on the cut surface. Similar defects will result when the cutting oxygen pressure is too high.

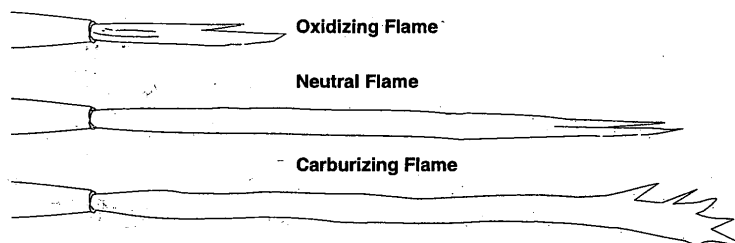

5.3 Cutting and piercing method

1. Cut in from the end of steel plate.
2. Pierce steel plate before cutting.
3. Drill a hole before cutting.

■ Piercing method

- 1) Ignite and adjust the flame.
- 2) Thoroughly preheat the cut-in point until it is white hot.
- 3) Open the cutting oxygen valve to pierce the steel plate. The tip should be about 15-20 mm from the plate to prevent slag from splashing onto the tip and adhering there, which will shorten the working life of the tip.

5.4 Procedure for starting cutting and the method of extinguishing fire (Pattern cutting)

1. Set the pressure switch in the interlocked position.
2. Set the drive switch in the left or right position.
3. Open the pressure switch valve of the torch.
4. Open the gas valve, slightly open the preheating oxygen valve, and ignite the gas with a lighter. Then fully open the gas valve immediately. (The gas valve may not be opened fully in some cases high-quality cutting). Make a neutral flame by controlling the preheating oxygen valve.
5. Control the distance between the tip from the steel sheet. Keep the tip of the white point 2-3mm away from the steel sheet.
6. After sufficiently preheating the edge of the steel sheet or the small hole made in advance for starting cutting, open the cutting oxygen valve. When the valve is opened, the pressure switch is activated simultaneously, and the motor turns to drive the magnet roller.
7. Move the magnet roller by hand to the template (while cutting), bring the roller in close contact with the template, and begin cutting.
8. After beginning cutting, carefully check the cutting condition to find the optimum cutting speed.
9. When the cutting tip returns to the starting point, immediately close the cutting oxygen valve, and the magnet roller stops simultaneously. Then close the gas valve and preheating oxygen valve in this order, and return the drive switch to the stop position. (It is not necessary to return to the stop position when cutting operation is to be continued.)

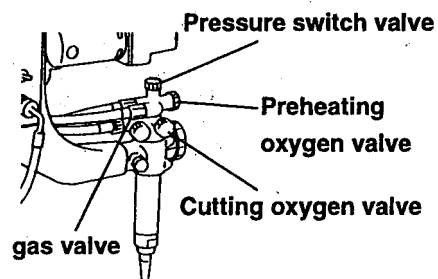

5.5 Cutting operation

1. Attach the machine to the cutting section, and align the tip with the cutting start-up point.
 2. Ignite the gas from the tip, and conduct preheating sufficiently.
 3. Open the cutting oxygen valve, and the pressure switch will be activated simultaneously. Then the magnet roller is driven, and cutting operation begins.
 4. Check the cutting condition, and control the cutting speed by means of the speed control knob so that it will be optimum.
 5. After cutting, close the cutting oxygen valve, fuel gas valve, and preheating oxygen valve in this order.
- ※Then repeat operation from the beginning.

5.6 Option

5.6.1 Large pattern cutting

When cutting a large pattern (600-1700 dia.), attach a tracing template to the main spindle for pattern cutting all around the main spindle. When attaching a tracing template to the main spindle, loosen the bolt atop the main spindle, and remove the upper part of the main spindle. Then remove the nut, place the template mounting plate on the bearing retainer, and secure the tracing template with the nut.

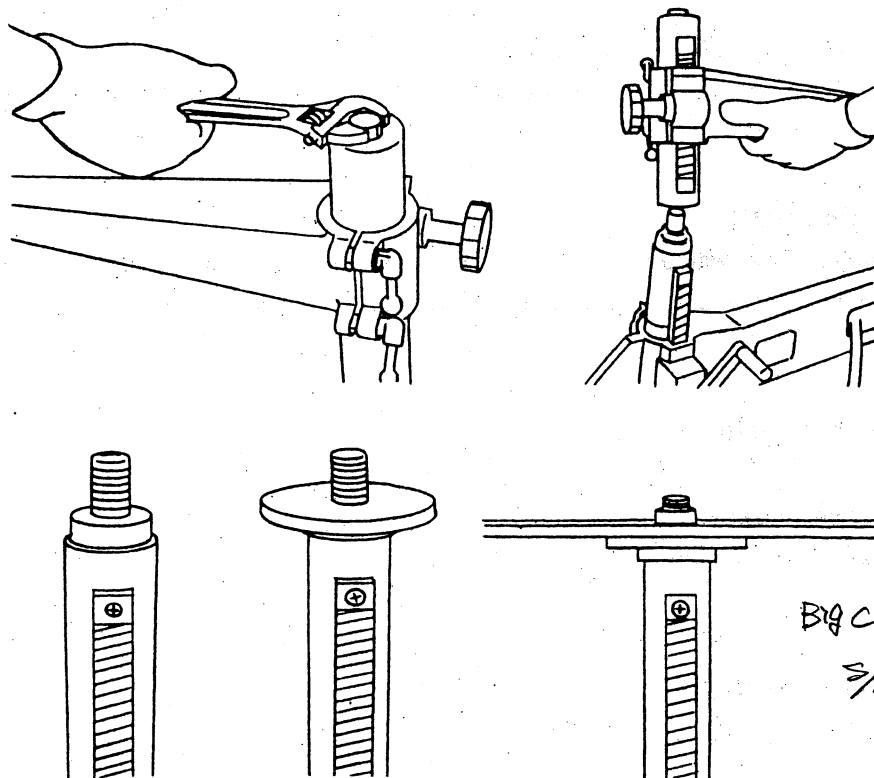

5.6.2 Changing magnet roller

When the dimension of the same shape is slightly different (due to change in thickness or tip) or when sharp corner is necessary, change magnet rollers. A 10-dia. magnet roller is attached to the machine as standard equipment, and 6-, 8-, 15-, and 20-dia. rollers are provided as well. When changing rollers, hold the aluminum magnet case by hand, and turn the hexagonal section of the magnet roller with a spanner.

5.6.3 Circle cutting attachment

This attachment is composed of a motor for turning, clutch mechanism, and circle diameter control holder. The attachment is to be mounted on the end of the arm in the upper section of the IK-54.

A rotary holder is connected to the rotary center of the No.1 arm and the MG roller, and the rotary motion is transmitted to the No.1 arm for circle cutting.

Effective cutting dia. ... 60-400 dia.

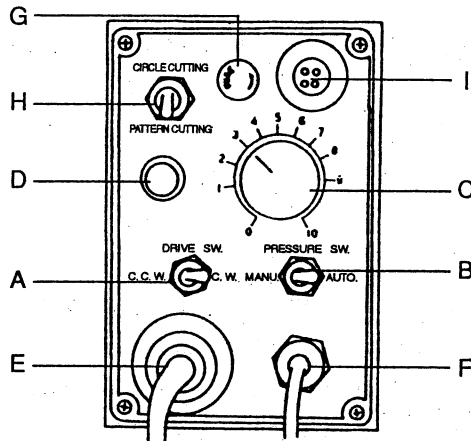

H. Changeover switchCircle/pattern cutting

When the two-position changeover switch is in the pattern cutting position, the No.1 arm drive unit rotates for pattern cutting. The circle cutting position is used when a circle cutting attachment is mounted on the upper arm.

I. Circle cutting receptacle

For power supply to the circle cutting attachment.

6 Maintenance and inspection

Refer to the following points for maintaining and inspecting the machine in order to use the machine under the best conditions.

6.1 Daily inspection

1. Clean the magnet roller with a brush at all times, because iron powder tends to adhere to it.
2. Always clean the tip to ensure satisfactory cutting oxygen flow and flame.

6.2 Monthly inspection

1. Check respective screws for loosening.
2. Oiling condition of the sliding and rotary sections (excl. torch section).

6.3 3-month inspection

1. Inspection of the magnet roller (abrasion)

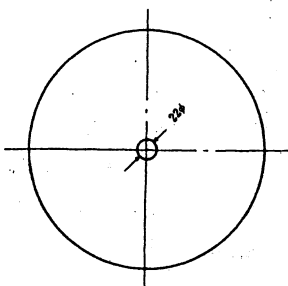

A large cutting template (a circle for example as shown in the figure) needs a 22-dia. hole in the center of the template.

7 Troubleshooting

Phenomenon	Cause	Correction
The drive unit will not turn	1) Defective receptacle	Check the wire soldering condition
	2) Defective switch	Check the wire connection, and check the switch with a tester
	3) Defective connection	Check the soldered section
	4) Disconnected lead wire	Check the lead wire with a tester
	5) Switch operation error	The pressure switch is not operating. (Oxygen is not supplied to the pressure switch.)
Poor accuracy	1) Poor arm accuracy	Trace the circular tracing plate (Repair)
	2) Curved torch	Replacement
	3) Eccentric magnet roller	Trace the straight ruler to check the accuracy. (Replace)
	4) Improper tightening of the template holding arm and excessive clearance	Check the cause of excessive clearance. Replace it when abraded
	5) Improper tightening of the template holder and excessive clearance	Check the cause of excessive clearance. Replace it when abraded
	6) Improper template dimensions or mounting	Correction
	7) Improper way of placing the cut material	Check that the cut material is placed at right angles to the torch
Defective cut surface	1) Improper motor rotation	Check or replace the control unit
	2) Excessive play of drive gear	Repair
	3) Improper cutting date	Decrease the cutting speed lower than specifications in the Cutting Data
	4) External vibration	Eliminate the vibration

Note:

Protection of the over load.

When the motor was locked by any reason, the motor rotation will be stopped after about four second.

(Recovery: Please turn on the power supply again.)

8 Wiring diagram

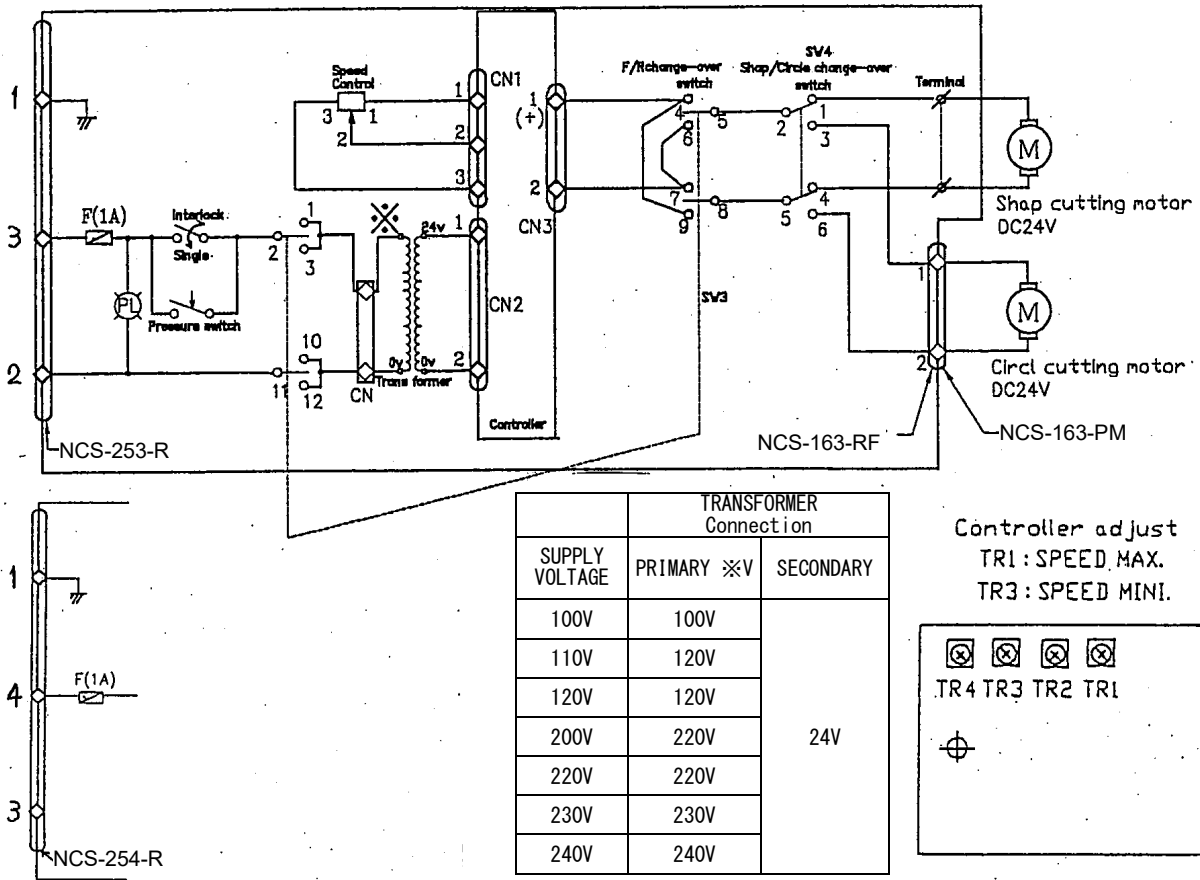

9 Assembly drawing of IK-54D

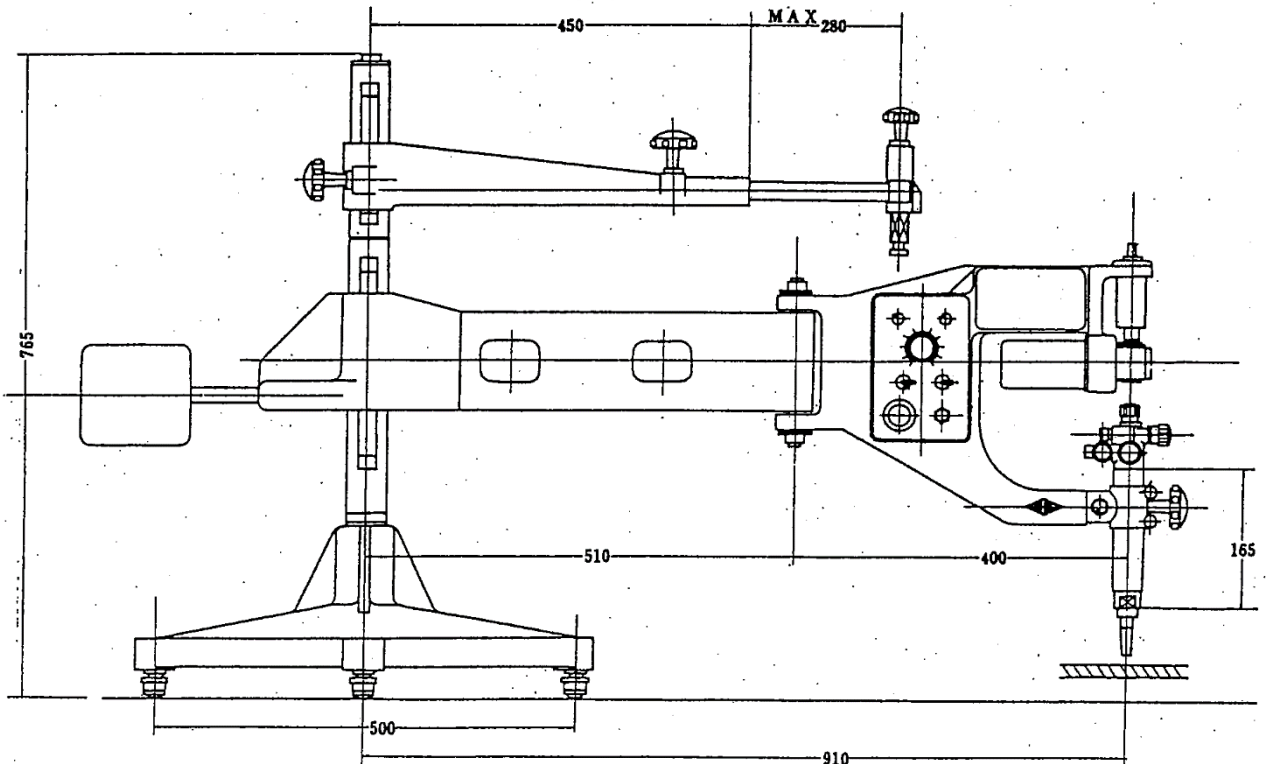

10 Parts list

10.1 Gear case, No.1 arm unit

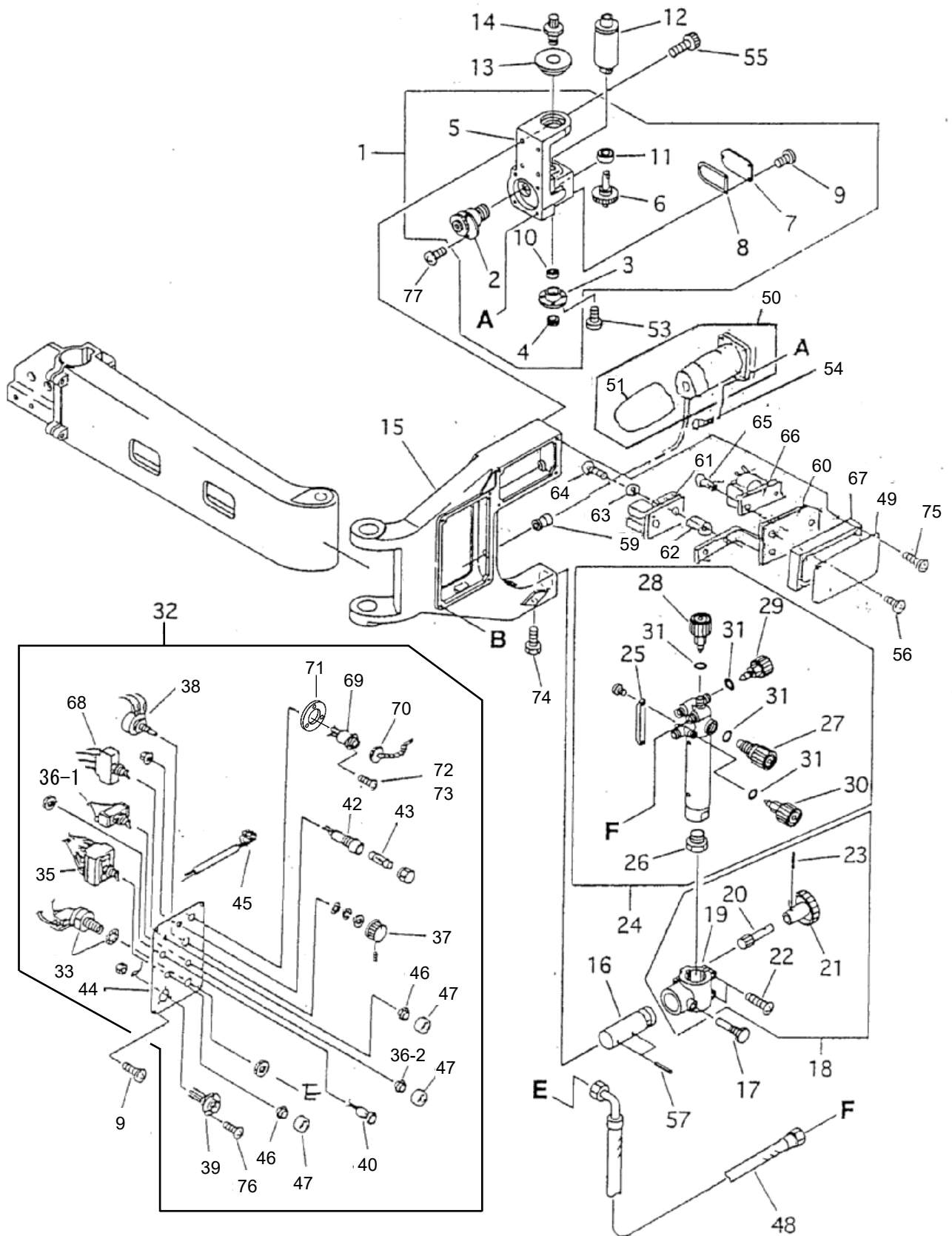

Gear case, No.1 arm unit

ITEM NO.	PART NAME	QTY	STOCK NO.	REMARKS	ITEM NO.	PART NAME	QTY	STOCK NO.	REMARKS
1	Gear case assembly(A)	1	60032200		36	Switch assembly	1	61006769	S-1A With nut
2	Gear assembly	1	60030712		36-1	Switch	1	61006768	S-1A
3	Flange	1	60030713		36-2	Dust protective nut	1	60032480	S-1A only
4	Bearing retainer	1	60030714		37	Knob	1	60030744	With screw
5	Gear case	1	60030715		38	Variable resistor	1	60030745	
6	Worm wheel assembly	1	60030716		39	Metal socket	1	6N100061	3P AC100V
7	Gear cover	1	60030719			Metal socket	(1)	6N100062	4P AC200V-AC240V
8	Packing	1	60030720		40	Lamp holder	1	6N380009	AC100V-AC120V
9	Screw	7	6C520310	SP-3x10		Lamp holder	(1)	61001130	AC200V-AC240V
10	Bearing	1	6A030606	606ZZ	42	Fuse holder	1	64000019	
11	Bearing	1	6A030608	608ZZ	43	Fuse	1	60030707	1A
12	Magnet bobbin	1	60030717	SP-4x10 2pcs	44	Operation panel	1	60030834	
13	Magnet bracket assembly	1	60030718		45	Terminal	1	60031666	2P
14	Magnet roller	1	60030721	φ 10 standard	46	Dust protective nut	2	60032480	
	Magnet roller	(1)	60030722	φ 6	47	Dust protective cap	3	60032431	
	Magnet roller	(1)	60030723	φ 8	48	Hose for pressure switch	1	60032238	Except USA
	Magnet roller	(1)	60030724	φ 15		Hose for pressure switch	(1)	60030731	USA only
	Magnet roller	(1)	60030725	φ 20	49	Name plate	1	60032205	
15	No.1 arm	1	60030726		50	Motor	1	61007882	DC24V
16	Torch holder bar	1	60030728	※1	51	PCV cap	1	64000128	
17	Holder bolt	1	60030729		53	Screw	4	6C520410	SP-4x10
18	Torch holder assembly	1	60032203		54	Screw	4	6C520415	SP-4x15
19	Torch holder	1	60030727		55	Screw	4	6C030625	BC-6x25
20	Pinion	1	60030732	※1	56	Screw	2	6C520408	SP-4x8
21	Handle	1	60030317	※1	57	Spring pin	2	6B024040	PR-4x40
22	Screw	2	6C520520	SP-5x20	58	Screw	2	6C500306	SF-3x6
23	Spring pin	1	6B022516	PR-2.5x16	59	Cord bush	1	60032575	
24	Torch	1	60010801	Except USA,KE	60	Bracket	1	61001083	
	Torch	(1)	60010802	USA only	61	Controller	1	69000105	
	Torch	(1)	60010807	KE only	62	Spacer	2	6R020001	
25	Rack for torch	1	60010803	With screw	63	Insulation washer	2	60036374	
26	Tip fixing nut	1	60005020		64	Screw	2	6C520310	SP-3x10
27	Valve for Jet oxygen	1	60015416	Except KE	65	Screw	2	20548792-Y	SP-3X5 (with WS,WF)
	Valve for Jet oxygen	(1)	60015417	KE only	66	Transformer	1	61000472	AC100V-AC220V
28	Pressure valve	1	60015354	Except KE		Transformer	(1)	61000672	AC230V-AC240V
	Pressure valve	(1)	60015358	KE only	67	Spacer	1	61001107	
29	Valve for Preheat oxygen	1	60015355	Except KE	68	Switch	1	60030822	S-332
	Valve for Preheat oxygen	(1)	60015358	KE only	69	Metal socket	1	6N100049	3P
30	Valve for gas	1	60015356		70	Cap	1	60030824	
31	O-ring	4	6E900001		71	Receptacle spacer	1	61007621	
32	Operation panel assembly	1	61004234	AC100V	72	Screw	1	6C500308	SF-3x8
	Operation panel assembly	(1)	61004238	USA only AC120V	73	Screw	2	6C500310	SF-3x10
	Operation panel assembly	(1)	61004252	AC200V-AC240V	74	Screw	1	6C520610	SP-6X10
33	Pressure switch	1	60030736		75	Screw	4	6C520320	SP-3X20
	Pressure switch	(1)	60030737	USA only	76	Screw	1	6C500310	SF-3X10
35	Switch	1	60031458	S-43	77	Screw	2	6C530410	M4X10 with WS

※1 It is necessary to drill and pin the holes to match the actual product.

Note: When replacing parts, the horizontal and vertical directions are There is a possibility of deviation.

10.2 Upper arm · Main spindle unit

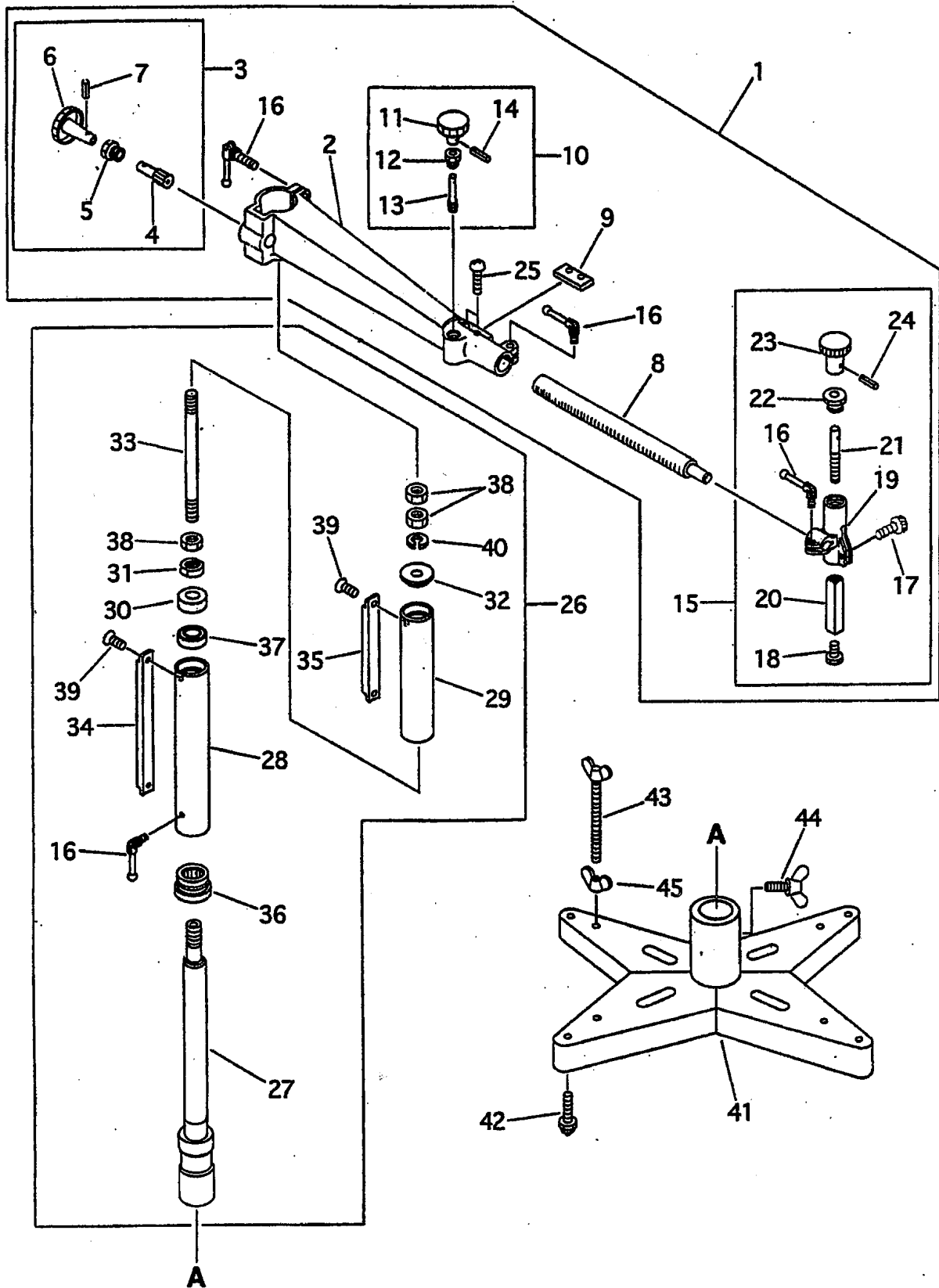

Upper arm ・ Main spindle unit

ITEM NO.	PART NAME	QTY	STOCK NO.	REMARKS	ITEM NO.	PART NAME	QTY	STOCK NO.	REMARKS
1	Upper arm assembly	1	60030701		33	Set bolt	1	60030788	
2	Upper arm base	1	60030767		34	Rack(A)long	1	60030784	
3	Handle assembly(B)	1	60032202		35	Rack(B)short	1	60030785	
4	Pinion	1	60030768	※1	36	Bearing	1	60030786	NAX3030Z
5	Pinion metal	1	60030769		37	Bearing	1	6A036004	6004ZZ
6	Handle(φ 50)	2	60030317	※1	38	Nut	3	6D010120	NH-12
7	Spring pin	3	6B022516	PR-2.5x16	39	Screw	4	6C500510	SF-5x10
8	Slide bar	1	60030770		40	Spring washer	1	6D500120	WS-12
9	Key	1	60030771		41	Stand assembly	1	60030708	
10	Handle holder	1	60030772		42	Idle wheel unit	4	60030709	
11	Handle(φ 50)	2	60030317	※1	43	Wing bolt	2	6C111130	BS-10x130 With Nut
12	Pinion metal	1	60030909		44	Wing bolt	1	6C110825	BS-8x25
13	Pinion	1	60030910	※1	45	Wing nut	2	6D080100	NB-10
14	Spring pin	3	6B022516	PR-2.5x16					
15	Template holder unit	1	61004812	W22					
16	Crank handle	5	60030313	M8x20					
17	Hexagon bolt	1	6C030615	M6x15					
18	Template set bolt	1	60030773						
19	Vertical slide base	1	60030566						
20	Slide bar	1	60030775						
21	Slide screw	1	60030776	※1					
22	Pinion metal	1	60030564						
23	Speed adjusting handle	1	60030223	※1					
24	Spring pin	3	6B022516	PR-2.5x16					
25	Screw	2	6C520320	SP-3x20					
26	Main spindle assembly	1	60030702						
27	Main spindle	1	60030778						
28	Rotaly pipe	1	60030779						
29	Set pipe	1	60030780						
30	Bearing retainer	1	60030781						
31	Nut	1	60030782						
32	Pipe set plate	1	60030783						

※1 It is necessary to drill and pin the holes to match the actual product.

10.3 No. 2 arm · Weight

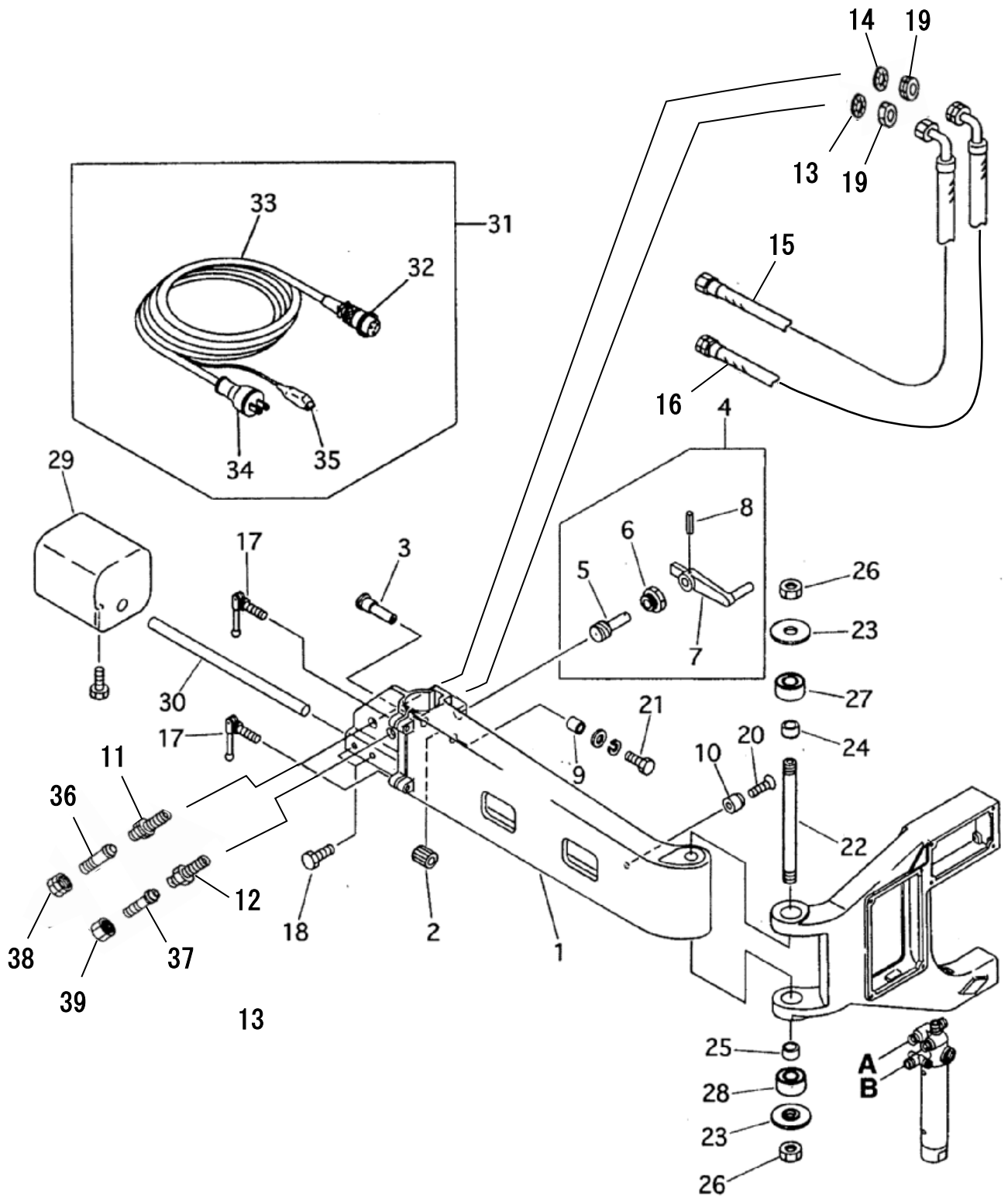

No.2 arm · Weight

ITEM NO.	PART NAME	QTY	STOCK NO.	REMARKS	ITEM NO.	PART NAME	QTY	STOCK NO.	REMARKS
1	No.2 arm	1	60030753		27	Bearing	1	6A036902	6902ZZ
2	G-gear	1	60030945		28	Bearing	1	6A036202	6202ZZ
3	G-gear shaft	1	60030946		29	Weight	1	60030710	
4	Up/Down feed handle assembly	1	60032133		30	Weight bar	1	60030711	
5	G-pinion	1	60030948	※1	31	Cabtyre cord A'ssy (3P)	1	61004264	
6	G-pinion metal	1	60030949			Cabtyre cord A'ssy (4P)	1	61004306	For transformers
7	Handle	1	60032529	※1		Cabtyre cord A'ssy (3P)	1	61004272	No plug type
8	Spring pin	1	6B023030	PR-3x30		Cabtyre cord A'ss y(4P)	1	61004271	Din type
9	G-collar	1	60030947			Cabtyre cord A'ss y(3P) CE type	1	61005385	KE only No plug type
10	Rubber packing	1	60030754			Cabtyre cord A'ssy (4P) CE type	1	61005384	KE only DIN type
11	Nipple for oxygen	1	60030755	Except USA	32	Metal plug	1	6N100056	3P AC100V
	Nipple for oxygen	1	60030756	USA only		Metal plug	1	6N100057	4P AC200V-AC240V
12	Nipple for gas	1	60030757	Except USA	33	Cabtyre cord (5M)	1	61004458	
	Nipple for gas	1	60030758	USA only		Cabtyre cord (5M)	1	61005393	KE only CE type
13	Lock nut (OX)	1	60030759	Except USA	34	Rubber plug	1	60030280	
	Lock nut (OX)	1	60030760	USA only		DIN plug	1	64000183	
14	Lock nut (GAS)	1	60030761	Except USA	36	Hose connector (OX)	1	60015003	Except USA
	Lock nut (GAS)	1	60030762	USA only		Hose connector (OX)	1	60015040	KE only
15	Hose for oxygen	1	60032237	Except USA	37	Hose connector (GAS)	1	60015004	Except USA
	Hose for oxygen	1	60030764	USA only		Hose connector (GAS)	1	60015062	KE only
16	Hose for gas (Red)	1	60030765	Except USA	38	Nut for oxygen	1	60015001	Except USA
	Hose for gas	1	60030766	USA only		Nut for oxygen	1	60015056	KE only
	Hose for gas (Orange)	1	61001816		39	Nut for gas	1	60015002	Except USA
17	Crank handle	2	60032211	M8x25		Nut for gas	1	60015054	KE only
18	Hexagon bolt	2	6C021025	BH-10x25	40	Hexagon bolt	1	6C021030	BH-10x30
19	Washer	2	6D550160	WF-16					
20	Screw	1	6C520418	SP-4x18					
21	Hexagon bolt	1	6C020815	BH-8x15					
	Washer	1	6D510080	WS-8					
	Washer	1	6D500080	WF-8					
22	Arm shaft	1	60030794						
23	Bearing retainer	2	60030795						
24	F-Collar	1	60030796						
25	H-Collar	1	60030797						
26	Hexagon nut	2	60030798						

※1 It is necessary to drill and pin the holes to match the actual product.

11 Cutting data

102(STANDARD SPEED) For Acetylene

PLATE THICKNESS (mm)	TIP SIZE	CUTTING SPEED (mm/min)	OXYGEN PRESSURE (kg/c m ²) / (Mpa)		FUEL GAS PRESSURE (kg/c m ²) / (Mpa)	KERF WIDTH (mm)
			CUTTING	PREHEAT		
3	00	680	1.5 / 0.15	1.5 / 0.15	0.2 / 0.02	1.0
6	0	610	2.0 / 0.2	2.0 / 0.2	0.2 / 0.02	1.3
10	0	560	2.0 / 0.2	2.0 / 0.2	0.2 / 0.02	1.5
12.5	1	530	2.5 / 0.25	2.5 / 0.25	0.2 / 0.02	1.8
19	2	460	3.0 / 0.3	3.0 / 0.3	0.25 / 0.025	2.0
25	2	430	3.0 / 0.3	3.0 / 0.3	0.25 / 0.025	2.0
38	3	355	3.0 / 0.3	3.0 / 0.3	0.25 / 0.025	2.3
50	4	320	3.0 / 0.3	3.0 / 0.3	0.25 / 0.025	2.8

102-D7(HIGH SPEED) For Acetylene

PLATE THICKNESS (mm)	TIP SIZE	CUTTING SPEED (mm/min)	OXYGEN PRESSURE (kg/c m ²) / (Mpa)		FUEL GAS PRESSURE (kg/c m ²) / (Mpa)	KERF WIDTH (mm)
			CUTTING	PREHEAT		
3	00	800	7.0 / 0.7	1.5 / 0.15	0.2 / 0.02	0.8
6	0	740	7.0 / 0.7	2.0 / 0.2	0.2 / 0.02	1.0
10	0	680	7.0 / 0.7	2.0 / 0.2	0.2 / 0.02	1.3
12.5	1	630	7.0 / 0.7	2.5 / 0.25	0.2 / 0.02	1.3
19	2	560	7.0 / 0.7	3.0 / 0.3	0.25 / 0.025	1.5
25	2	510	7.0 / 0.7	3.0 / 0.3	0.25 / 0.025	1.8
38	3	460	7.0 / 0.7	3.0 / 0.3	0.25 / 0.025	2.0
50	4	410	7.0 / 0.7	3.0 / 0.3	0.25 / 0.025	2.6

NOTE

- 1) All pressures are torch inlet pressures.
- 2) Oxygen purity is minimum of 99.7%.
- 3) Depending on the surface condition of the steel plate (scale, paint) either increase the fuel gas pressure or decrease the cutting speed. Also, when precision cutting is required, adjust all data.

106(STANDARD SPEED) For Propane

PLATE THICKNESS (mm)	TIP SIZE	CUTTING SPEED (mm/min)	OXYGEN PRESSURE (kg/c m ²) / (Mpa)		FUEL GAS PRESSURE (kg/c m ²) / (Mpa)	KERF WIDTH (mm)
			CUTTING	PREHEAT		
3	00	680	1.5 / 0.15	1.5 / 0.15	0.2 / 0.02	1.0
6	0	610	2.0 / 0.2	2.0 / 0.2	0.2 / 0.02	1.3
10	0	560	2.0 / 0.2	2.0 / 0.2	0.2 / 0.02	1.5
12.5	1	530	2.5 / 0.25	2.5 / 0.25	0.2 / 0.02	1.8
19	2	460	3.0 / 0.3	3.0 / 0.3	0.2 / 0.02	2.0
25	2	430	3.0 / 0.3	3.0 / 0.3	0.2 / 0.02	2.0
38	3	355	3.0 / 0.3	3.0 / 0.3	0.2 / 0.02	2.3
50	4	320	3.0 / 0.3	3.0 / 0.3	0.25 / 0.025	2.8

106-D7(HIGH SPEED) For Propane

PLATE THICKNESS (mm)	TIP SIZE	CUTTING SPEED (mm/min)	OXYGEN PRESSURE (kg/c m ²) / (Mpa)		FUEL GAS PRESSURE (kg/c m ²) / (Mpa)	KERF WIDTH (mm)
			CUTTING	PREHEAT		
3	00	800	7.0 / 0.7	1.5 / 0.15	0.2 / 0.02	0.8
6	0	740	7.0 / 0.7	2.0 / 0.2	0.2 / 0.02	1.0
10	0	680	7.0 / 0.7	2.0 / 0.2	0.2 / 0.02	1.3
12.5	1	630	7.0 / 0.7	2.5 / 0.25	0.2 / 0.02	1.3
19	2	560	7.0 / 0.7	3.0 / 0.3	0.2 / 0.02	1.5
25	2	510	7.0 / 0.7	3.0 / 0.3	0.2 / 0.02	1.8
38	3	460	7.0 / 0.7	3.0 / 0.3	0.2 / 0.02	2.0
50	4	410	7.0 / 0.7	3.0 / 0.3	0.2 / 0.02	2.6

NOTE

- 1) All pressures are torch inlet pressures.
- 2) Oxygen purity is minimum of 99.7%, propane is minimum of JIS Grade 3.
- 3) Depending on the surface condition of the steel plate (scale, paint) either increase the fuel gas pressure or decrease the cutting speed. Also, when precision cutting is required, adjust all data.

IK-54D (Pattern Cutter)
OPERATION MANUAL

Date of issue:	Jul.1996
2nd	Mar.2003
3rd	Mar.2004
4th	Dec.2004
5th	May.2006
6th	Jun.2007
7th	Jun.2007
8th	Jul.2007
9th	Sep.2007
10th	Oct.2008
11th	Dec.2008
12th	Jun.2010
13th	Oct.2010
14th	Dec.2010
15th	Mar.2012
16th	Dec.2012
17th	Apr.2014
18th	Apr.2015
19th	May.2016
20th	Nov.2016
21th	Aug.2017
22th	Dec.2017
23th	Jun.2019
24th	Nov.2020
25th	Dec.2023
26th	May.2024

KOIKE SANZO KOGYO CO., LTD.

Printed in Japan