

DIAGRAMS & PARTS LIST

IK-12max3 TORCH S-100



6W400003-3

DIAGRAM

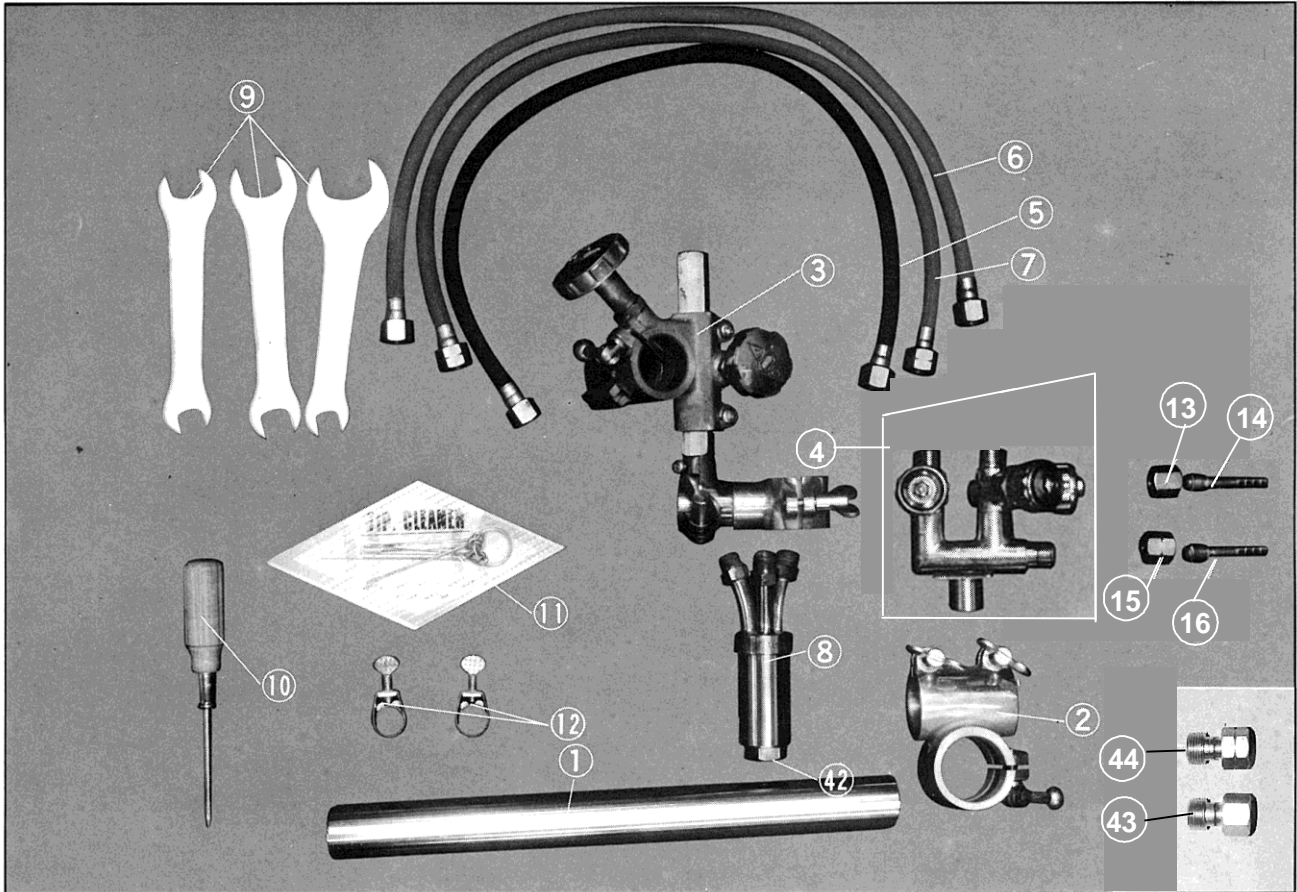

PARTS LIST

TEM No.	PART NAME	Qty	STOCK No.	REMARKS
1	Pipe arm	1	60030300	Standard 350mm
2	Bar holder assembly	1	60030301	
3	Torch holder (B Type)	1	60030302	
4	Distributor assembly	1	60013201	Except USA KE
			60013202	USA only
			60013205	KE only
5	Hose for jet oxygen	1	60030303	Except USA KE
			60030304	USA only
			60030305	KE only
6	Hose for preheat oxygen	1	60030305	Except USA
			60030306	USA only
7	Hose for gas	1	60030307	Except USA
			60030308	USA only
8	Torch	1	60010601	Except USA KE
			60010602	USA only
			60010606	KE only

ITEM No.	PART NAME	Qty	STOCK No.	REMARKS
9	Spanner	1	60030309	
10	Screwdriver	1	60030310	
11	Tip cleaner	1	60030311	
12	Hose band	2	60030312	Except USA
13	Nut for oxygen	1	60015001	Except USA KE M16 P1.5
			60015056	KE only
14	Hose connector for oxygen	1	60015003	Except USA KE 5/16
			60015040	KE only
15	Nut for gas	1	60015002	Except USA KE M16 P1.5Left
			60015054	KE only
16	Hose connector for gas	1	60015004	Except USA KE. 3/8
			60015062	KE only
43	Hose joint	1	60012917	KE only
44	Hose joint	1	60012904	KE only



IK-12max3 TORCH S-100

DIAGRAM

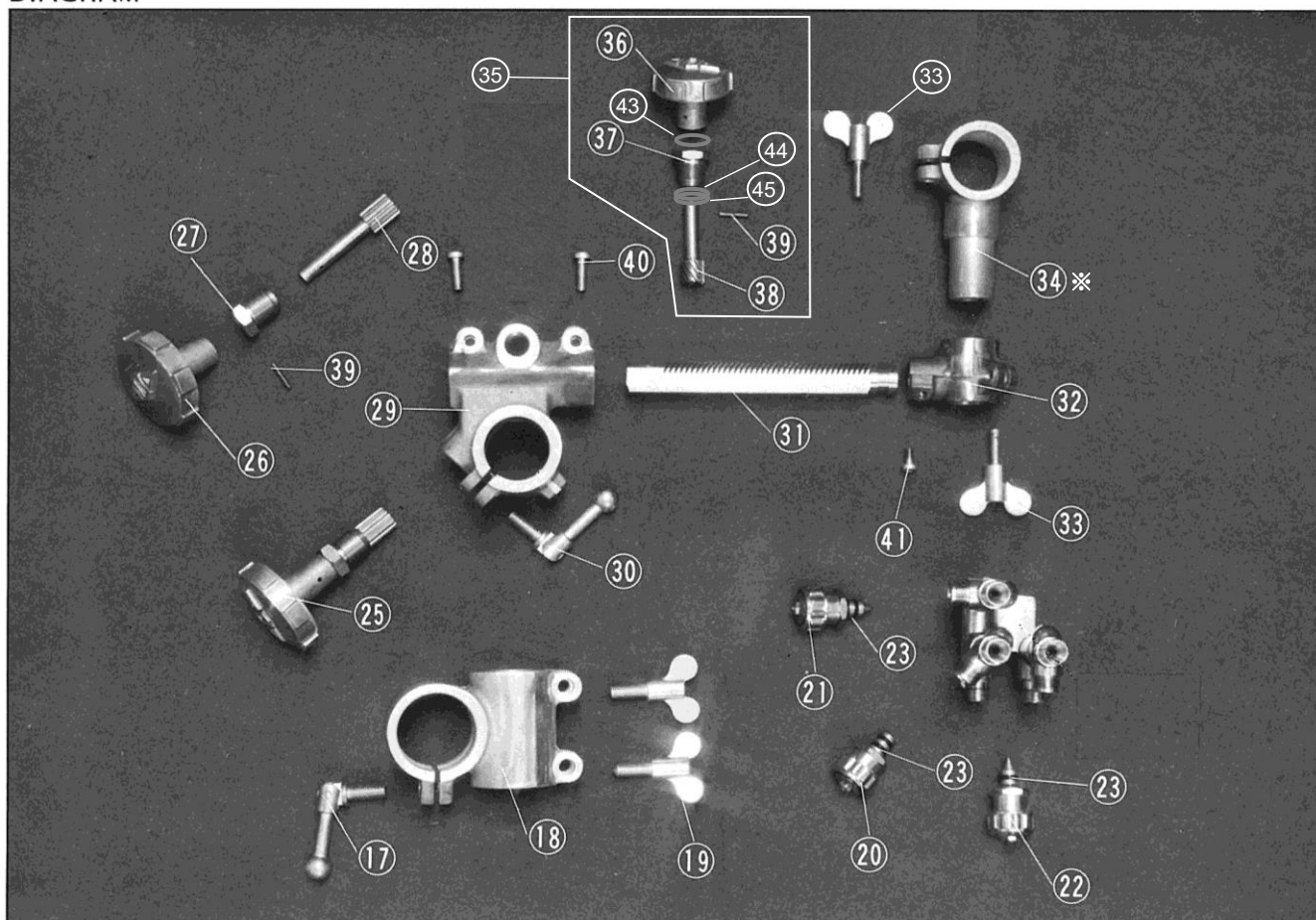

※ We have marked a line to match the scale, but we do not guarantee accuracy.
Please use this as a guide.
The line is not attached when purchasing individual parts. Mark it when replacing parts.

PARTS RIST

ITEM No.	PART NAME	Qty	STOCK No.	REMARKS
17	Crank handle	1	60030313	M8
18	Arm holder	1	60030314	
19	Wing bolt	2	60030315	M8
20	Valve for jet oxygen	1	60015251	
			60015252	KE only ★
21	Valve for preheat oxygen	1	60015255	
			60015258	KE only ★
22	Valve for gas	1	60015256	
23	O-Ring		6E900001	KS-5 ★
25	Cross feed handle assembly	1	60030316	
26	Handle	1	60030317	φ 50
27	Pinion metal	1	60030318	
28	pinion	1	60030319	
29	Cross feed unit	1	60030320	With key
30	Crank handle	1	60030313	

ITEM No.	PART NAME	Qty	STOCK No.	REMARKS
31	Slide bar	1	60030390	
32	Torch holder bracket	1	60030391	
33	Wing bolt	2	60030392	
34	Torch holder	1	60030393	※
35	Up/down handle assembly	1	60030394	
36	Handle	1	60030223	
37	Pinion metal	1	60030395	
38	Pinion	1	60030396	
39	Spring pin	2	6B022516	PR-2.5×16
40	Screw	2	6C520618	SP-6×18
41	Screw	1	6C520510	SP-5×10
42	Tip fixing nut	1	60005020	
43	Washer	2	20521750	
44	Wave washer	1	6D530008	WW-8
45	Shim	1	60032329	



IK-12max3
TORCH S-100 OPERATION MANUAL

Date of issue:	May.2012
2 nd	Oct.2023
3 rd	Aug.2024
4 th	Oct.2024

KOIKE SANSO KOGYO CO., LTD

Printed in Japan